

irritec[®]

don't wait for rain[®]

SHAKER PRO
F E R T I G A T I O N M I X E R

USER MANUAL v2.0



Copyright Notice

This publication contains proprietary information belonging to IRRITEC® SpA.

This information is provided solely to help users who are expressly and properly authorized by IRRITEC® SpA. No part of this document may be used for any other purpose, divulged to any person or company, or reproduced by any means, electronic or mechanical, without the express written permission of IRRITEC® SpA.

The text and graphics contained in this document are for illustrative purposes only. All information contained is subject to change without notice. No part of this publication forms part of any contract or warranty unless specifically incorporated by reference into such contract or warranty.

The information contained in this publication is purely descriptive. It does not constitute a binding offer for the sale of the product described here in. The information contained in this publication is subject to change without prior notice. The corporate and individual names and data used in the examples shown herein are fictitious unless otherwise specified.

IRRITEC® SpA reserves the right to change the specifications and descriptions of the equipment in this publication without notice.

© 2025 IRRITEC® SpA. All rights reserved.

INTRODUCTION

1. SAFETY
 2. DESCRIPTION
 - 2.1 ADVANTAGES
 - 2.2 TECHNICAL SPECIFICATIONS
 - 2.3 UNIT COMPONENTS
 - 2.4 OPERATING PRINCIPLE
 3. INSTALLATION
 - 3.1 HYDRAULIC CONNECTIONS
 - 3.1.1 CONNECTION OF UNIT TO IRRIGATION MAINLINE (BYPASS)
 - 3.1.2 CONNECTION OF UNIT TO IRRIGATION MAINLINE (IN-LINE)
 - 3.1.3 CONNECTION OF EC-pH PROBE HOLDER
 - 3.1.4 INSTALLATION OF EC & pH SENSORS
 - 3.1.5 CONNECTION OF FERTILIZERS TANKS
 - 3.2 ELECTRICAL CONNECTIONS
 - 3.2.1 CONNECTION TO THE ELECTRICAL POWER SUPPLY
 - 3.2.2 CONNECTION OF MAIN IRRIGATION PUMP
 - 3.2.3 CONNECTION OF SYSTEM WATER METER
 - 3.2.4 CONNECTION OF IRRIGATION VALVES
 - 3.2.5 CONNECTION OF SOLAR RADIATION SENSOR
 - 3.2.6 CONNECTION OF MODEM, WIRED EXTENSION AND RADIO TRANSMITTER
 4. START-UP AND ADJUSTMENT
 - 4.1 OPENING THE HYDRAULIC CIRCUIT
 - 4.2 CHECKING OPERATION AND DIRECTION OF PUMP ROTATION
 - 4.3 CHECKING OPERATION, TESTING AND ADJUSTING OF SUCTION AND INJECTION CHANNELS
 - 4.4 CALIBRATING THE PROBES
 - 4.5 ADJUSTING THE UNIT
 5. PROGRAMMING
 6. MAINTENANCE
 7. TROUBLESHOOTING
- WARRANTY

***Attention**

Always read the safety instructions prior to installing Shaker Pro™ fertigation unit.

1. SAFETY

In addition to the required normal procedures and regulations, all rules of safety provided below must be observed and implemented.

The guarantee of operation and working efficiency provided by the instrument may be compromised if the device is used in any way other than that specified by the manufacturer.

Notes Power supply:

Ensure that the available power supply is suitable and complies with unit's requirements.

The electrical system must comply with current applicable rules of safety and regulations in the country of installation.

Installation and electrical connections must be carried out by authorized electrician or qualified technical personnel.

Ensure that there is an available electrical outlet in proximity to the **Shaker Pro™** for installation and service purposes.

Consult your supervisor or **Irritec®** technical personnel if any problems are experienced during the installation procedure.

Notes Installing the unit:

Installation must be carried out by authorized personnel only.

The bench should be installed out on a solid, level base or a flat, compact and level surface.

Do not apply excessive weight, force or pressure to components during the installation procedure.

Ensure that fertilizers and any corrective acid are available and on-site during installation.

Ensure that installation is carried out in such a way as to prevent any possible leakage of fertilizer/acid and to avoid any possible risk of contamination of the environment, soil or surrounding area.

Consult your supervisor or **Irritec®** technical personnel if any problems are experienced during the installation procedure.

When using acid (pH-correcting), always follow the safety instructions of the acid manufacturer.

When opening or closing any manual valve, do it slowly and gradually in order to not cause any damage to the system resulting from the effect of water hammer.

General notes:

Always use personal protective equipment (PPE) and tools suitable for the work being carried out.

Always use protective gloves and safety glasses when handling fertilizers, acids and other chemicals.

There are combinations of fertilizers which, when injected at high concentrations, could cause crystallization to occur in the manifold of the **Shaker Pro™** and result in clogging or malfunctions.

Always consult the product suppliers and specify the type of use and application.

Take all necessary measures to prevent the unwanted infiltration of acid and fertilizers (in water and soil), to avoid any form of water pollution.

If in doubt, always consult your supervisor or **Irritec®** technical personnel.

2. DESCRIPTION

The **Shaker Pro™** is a simple and powerful “all in one” irrigation and fertigation control machine designed by Irritec® to provide an accurate and reliable system, capable to guarantee optimal growth conditions to almost any crop. It is a valuable accessory for any farm that wants to approach automatic irrigation and fertigation in a simple and economical way and is suitable for both greenhouse and open field applications.

The unit is supplied assembled and ready to be connected to an existing irrigation system, which is hydraulically compatible with the operating requirements of the machine itself. The machine is equipped with a **Commander EVO® Gold** controller and integrated EC and pH probes, which allows the complete management of irrigation system including irrigation programs (by time and volume of water), fertigation (by volume of fertilizers, in proportion to irrigation water or by EC and pH targets), irrigation valves and pumps control, fertilizer mixing system control, automatic filters backwashing and also start of irrigation/fertigation process on demand by external switching device or by Solar Radiation sensor (not included).

In addition, using of **Farmonitor** web software makes **Shaker Pro™** the complete and easy to use solution for remote irrigation and fertigation management.

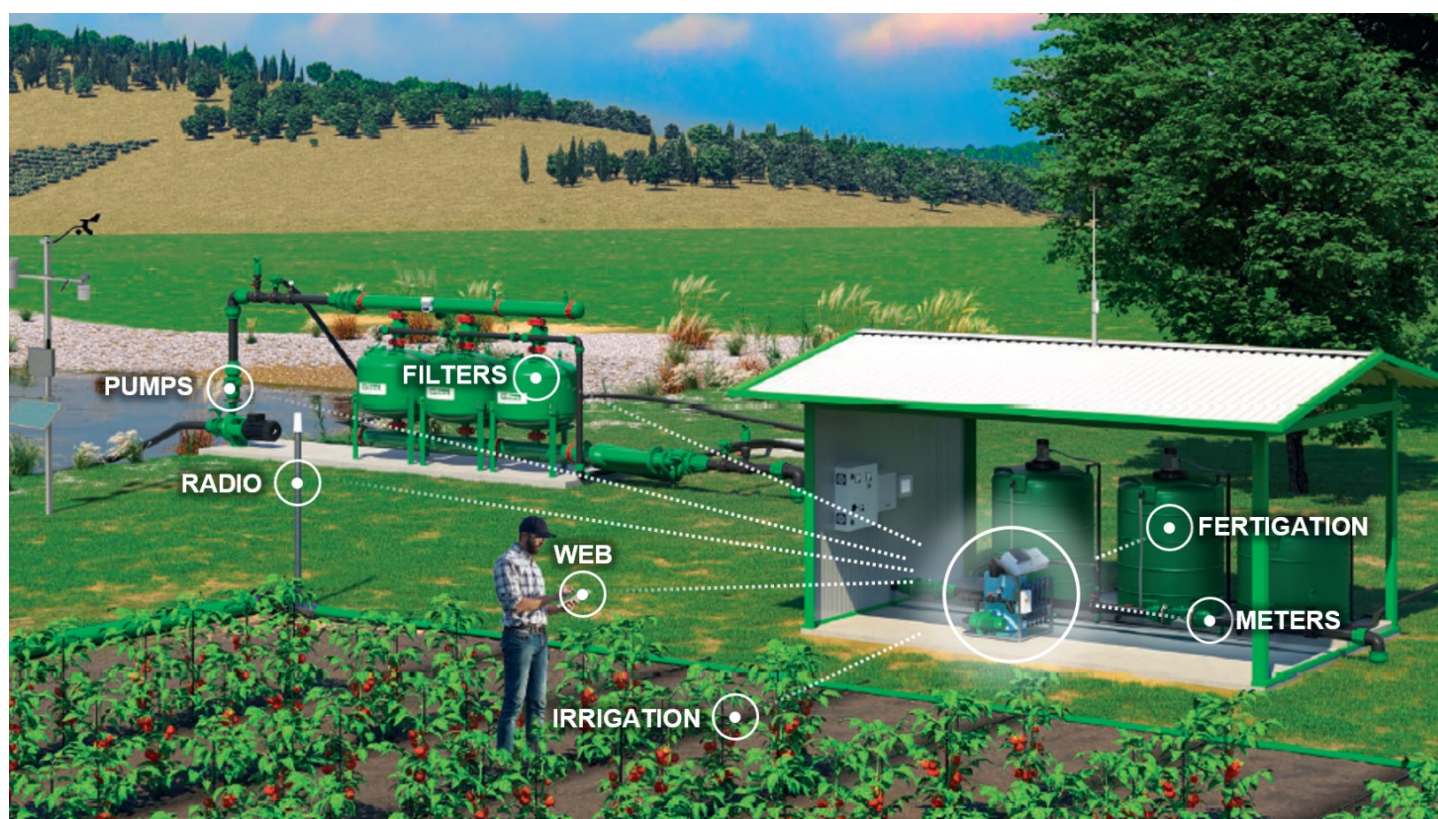

APPLICATIONS:



2.1 ADVANTAGES

- Full-functional irrigation & fertigation controller onboard.
- Equipped with pH and EC sensors and 100 l pre-mixing tank.
- From 2 to 4 dosing channels + acid dosing channel for automatic pH correction by setpoint.
- 3 modes of fertigation: by time/volume of fertilizers, proportional* (liters/m³), or EC target.
- Up to 64 independent irrigation blocks programmable, each with its set of irrigation valves and pumps.
- For each irrigation block – programmable irrigation by time or/and volume of water + fertigation parameters.
- Up to 20 independent irrigation programs, each with its sequence of irrigation blocks, schedule and start conditions.
- From 17 to 19 local outputs 24VAC, which can be programmed as irrigation valves, auxiliary pumps, filters and fertilizer mixer.
- Number of outputs 24VAC can be expanded up to 113 with wired extensions.
- Expandable with EVO Radio system for wireless control of up to 96 irrigation valves.
- Programming of filters backwashing by time/volume/DP, up to 10 filters configurable with different backwashing duration
- Automatic pause of irrigation and/or fertigation during backwashing process.
- Programmable delay for main irrigation pump and auxiliary pumps (up to 4 aux pumps)
- Adjustable fertigation parameters for precise correction of EC and pH.
- Irrigation/fertigation start by accumulated solar radiation or external command.
- Flow and fertilizers alarms: low flow, extra flow, no water, no fertilizer solution, EC/pH too high/low.
- Remote management of irrigation system using WEB software with adding GPRS or Wi-Fi modem.
- Statistics of water and fertilizers usage with export to Excel (by using WEB software).

***Attention**

**Please refer to Commander EVO® Gold user manual
for the detailed information about connectivity and control capabilities**

2.2 TECHNICAL SPECIFICATIONS:

*Attention

Always check carefully hydraulic parameters of irrigation system prior to installing the fertigation unit. For bypass installation pressure in the mainline must not exceed unit's booster pump maximum pressure.

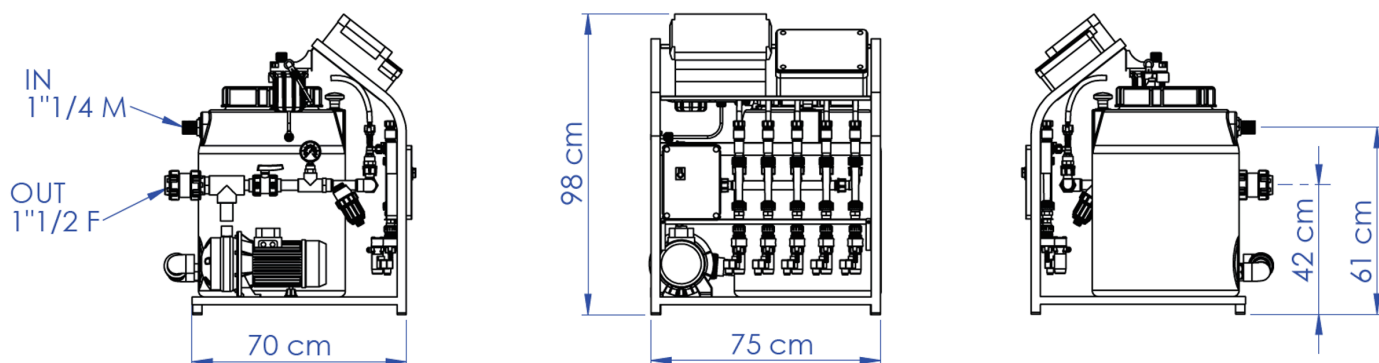

Dimensions (crate) & weight	80x120x80 cm - 75 kg
Power supply	3 x 380 Vac + Neutral + GND, 50 Hz, 16 A
Hydraulic connections	IN 1 ¼" M - OUT 1 ½" F, probe holder ½" M
Hydraulic installation	In-Line, Bypass
Booster pump	12 m ³ /h (in-line) or 4 m ³ /h (bypass), 37-64 m*
Dosing channels	2-4* fertilizers 500 l/h + 1 acid 350 l/h, productivity up to 750 l/h is available upon request
Injection mode	pH target + EC target / proportional / time / volume
Irrigation control mode	Time (hh:mm:ss) & volume of water (l or m ³), single valve or group of valves
Integrated EC sensor	0.2...20 mS (K=1), 0...7 bar, temperature compensation: NO
Integrated pH sensor	0...14 pH, 57 mV/ppm, 0...7 bar, temperature compensation: NO
Controller	Commander EVO® Gold
Controller's outputs	17-19* outputs 24 Vac + main pump output 24 Vac
Communications	2 x RS485 (for EVO® Radio transmitter and extensions), 1 x RS232 (for GPRS or Wi-Fi modem)

* depends of model

*Attention

For acid injection, use the dedicated dosing channel (marked on the unit), equipped with the appropriate components according to the type and concentration of acid used.

Exceeding the recommended acid concentrations will damage the dosing channels and impair proper functioning of the unit. Refer to the table of solutions and concentrations in the relevant installation section of this manual. If in doubt, always consult your supervisor or Irritec technical personnel.

2.3 UNIT COMPONENTS

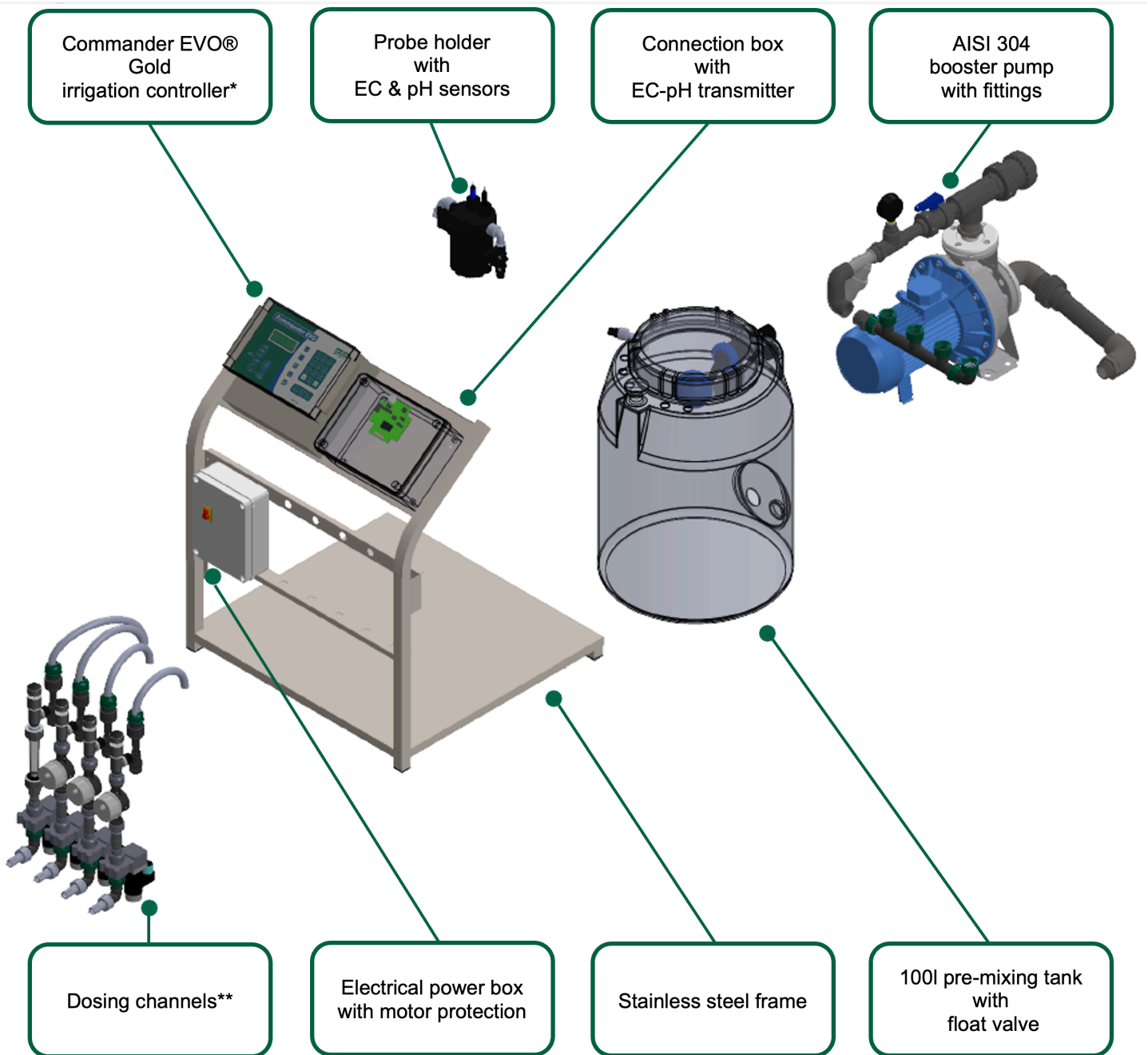

***Shaker Pro™** is supplied totally assembled and ready to install, with all electrical components already interconnected and **Commander EVO® Gold** controller pre-configured.

** All fertilizer dosing channels are equipped with electronic fertilizer meters, manual needle valves for smooth flow adjustment and special chemically resistant solenoid valves with EPDM membranes. Acid dosing channel is equipped with mechanical glass flowmeter and solenoid valve with Viton membrane, which is more resistant to acid.

2.4 OPERATING PRINCIPLE

The **Shaker Pro™** fertigation unit performs the dosing of different fertilizers and acid into the irrigation water mainline during the irrigation program. The suction of the fertilizers and acid into the dosing channels is based on the Venturi principle. The **Shaker Pro™** fertigation unit is equipped with special **Irritec®**-designed high-suction Venturis, which guarantee the exceptional performance for such application.

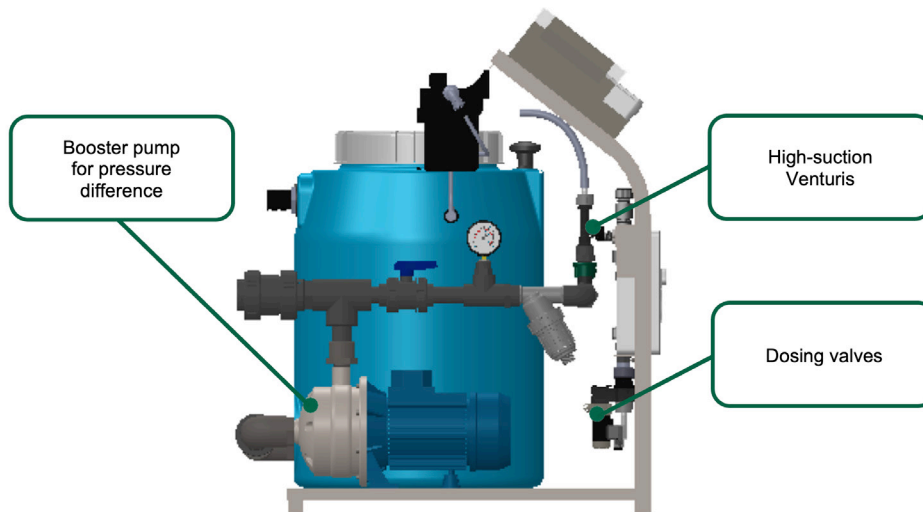

Pressure difference for Venturis is provided by the fertigation unit's design concept. Water from the irrigation mainline or another pressurized water source is supplied to the unit's inlet by filling the pre-mixing tank. Booster pump takes the water from pre-mixing tank and delivers it back to irrigation system, at the same time pressurizing the Venturis from upstream. Each Venturi's downstream has free discharge to pre-mixing tank. This pressure difference makes Venturis to inject fertilizers to pre-mixing tank, when opening corresponding dosing valve on Venturi's suction inlet.

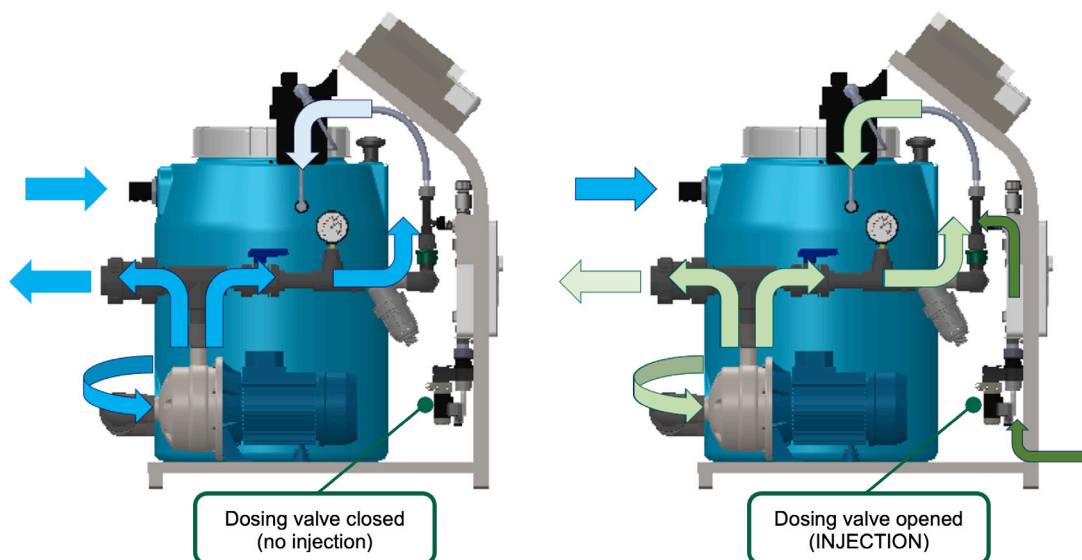

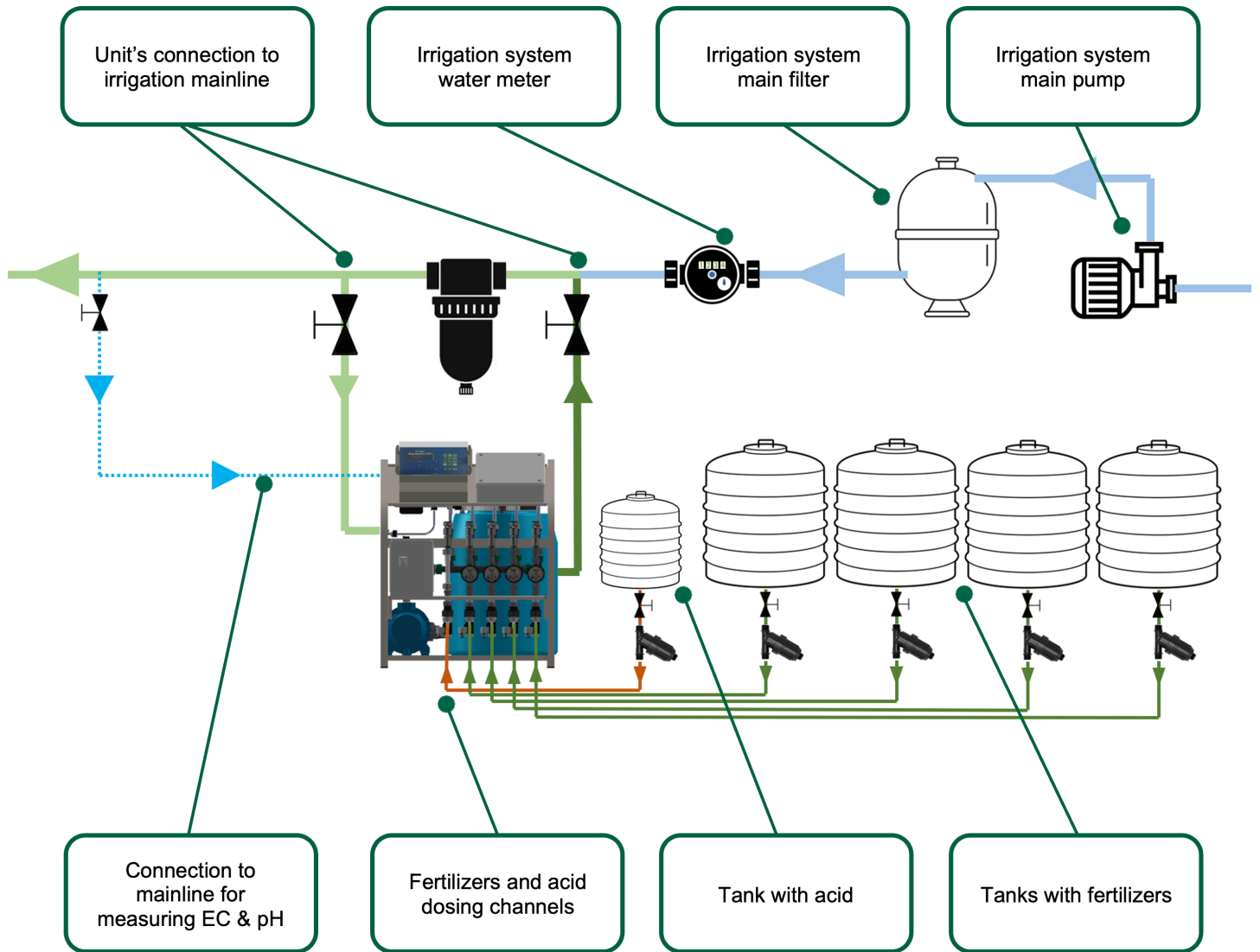

From the unit's premixing tank, the mixed solution is delivered to the irrigation system by booster pump. The constant circulation of water and fertilizers inside the premixing tank makes the dosing smoother and more precise, with reducing volume of fertilizers used. This dosing process is constant during the irrigation program, all dosing channels are independently and automatically managed by the **Commander EVO® Gold** controller in according to user's settings and to EC & pH measurements.

3.0 INSTALLATION

***Attention**
 Installation must be carried out only by authorized personnel.

***Attention**
 Before starting the installation procedure, please read the safety notes contained in the relevant section at the beginning of this manual.

3.1 HYDRAULIC CONNECTIONS

There are 2 ways of **Shaker Pro™** unit's installation, depending on irrigation system's flowrate and pressure – Bypass and In-Line. With In-Line installation unit's pump is used like main irrigation pump.

Installation	Irrigation system pressure, MAX	Irrigation system flowrate, MAX	Shaker Pro™ pump (50 Hz)
BYPASS	6.4 bar	200 m ³ /h*	4 m ³ /h, 3.9 – 6.4 bar
IN-LINE	3.7 bar	12 m ³ /h	12 m ³ /h, 3.7 bar

* it is necessary to consider maximum dosing capacity of single fertilizer channel 500 l/h with maximum dosing proportion 1:100 (1l of fertilizer for each 100l of water), total maximum capacity of 4 fertilizer channels is 2000 l/h.

3.1.1 CONNECTION OF UNIT TO IRRIGATION MAINLINE (BYPASS)

Connect inlet and outlet of fertigation unit to irrigation mainline pipe by using 2 clamp saddles (or tees) before (outlet) and after (inlet) safety filter, to protect the system from undissolved fertilizers. Always use bypass valves to be able to disconnect the unit from pressurized system and perform maintenance at any time. For the precise proportional dosing, unit must be installed after the system's main water meter.

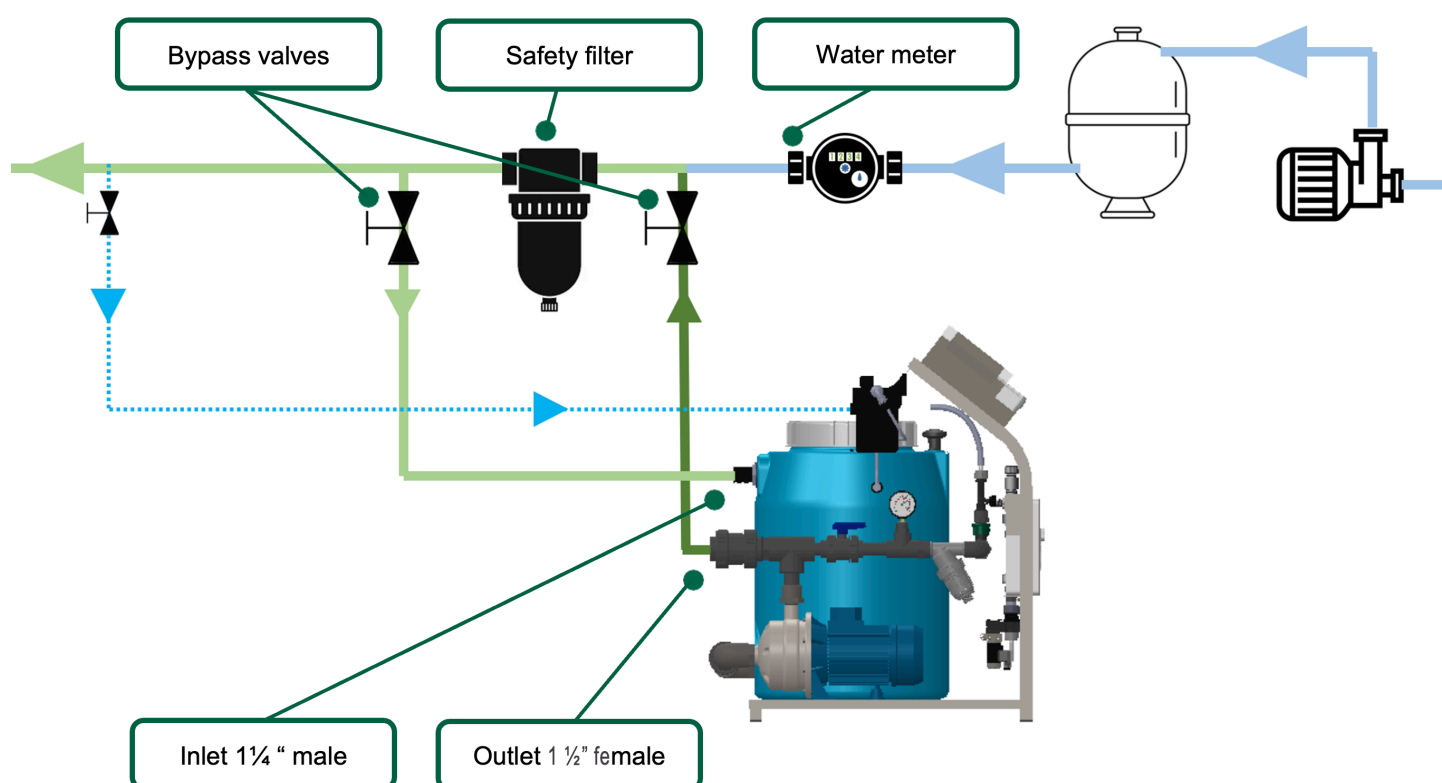

With bypass installation it is recommended to use Pressure Reducing valve (PRV) on unit's inlet to regulate the flow of water, supplied to premixing tank, and Pressure Sustaining valve (PSV) on unit's outlet to keep the needed pressure for venturis inside the fertigation unit.*

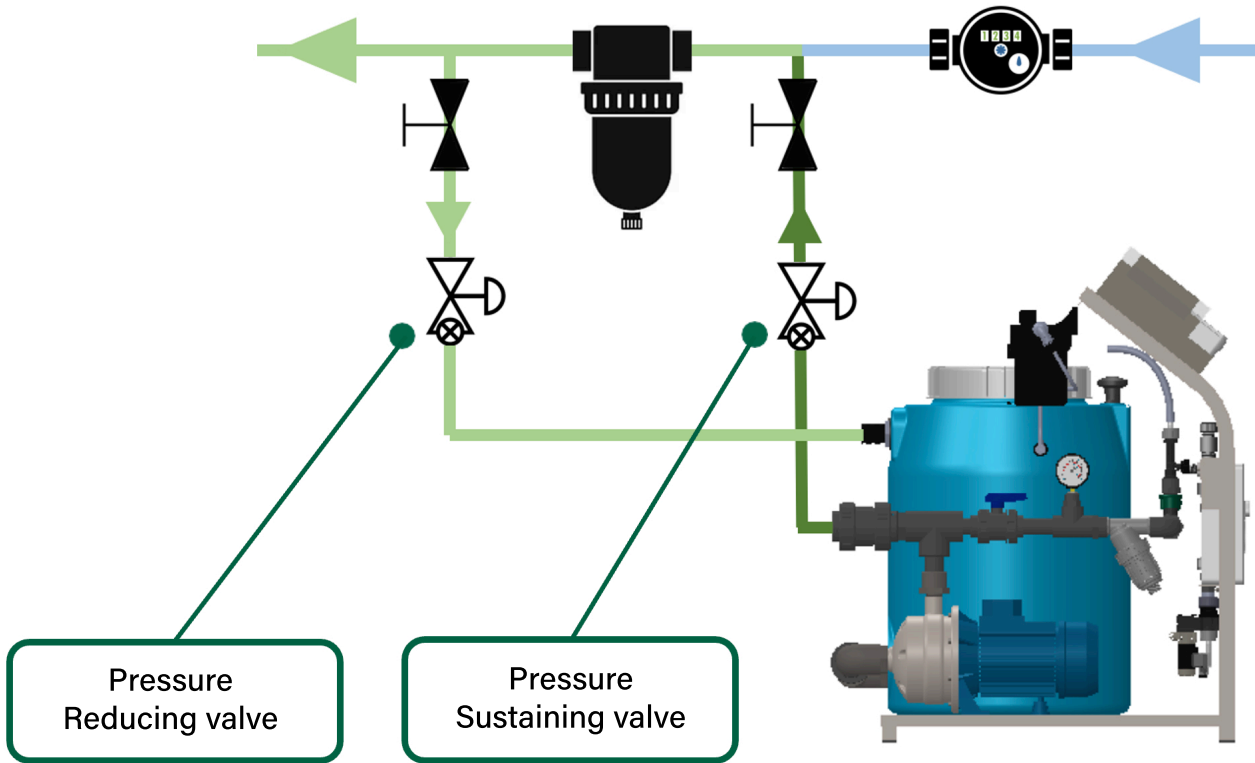

* PRV and PSV are not included in the Saker Pro™ supply, please contact your dealer or Irritec® supervisor for correct sizing and selection of valves.

3.1.2 CONNECTION OF UNIT TO IRRIGATION MAINLINE (IN-LINE)

If **Shaker Pro™** booster pump's flowrate and pressure are sufficient for the irrigation system requirements, the booster pump can be used as main irrigation pump. In this case a pressurized water source is needed to deliver water to unit's premixing tank, with flowrate equal to the **Shaker Pro™** booster pump's maximum flowrate*. Using of Pressure Reducing valve on inlet and Pressure Sustaining valve on outlet is also recommended for the in-line installation.

* see booster pump's parameters on page 11

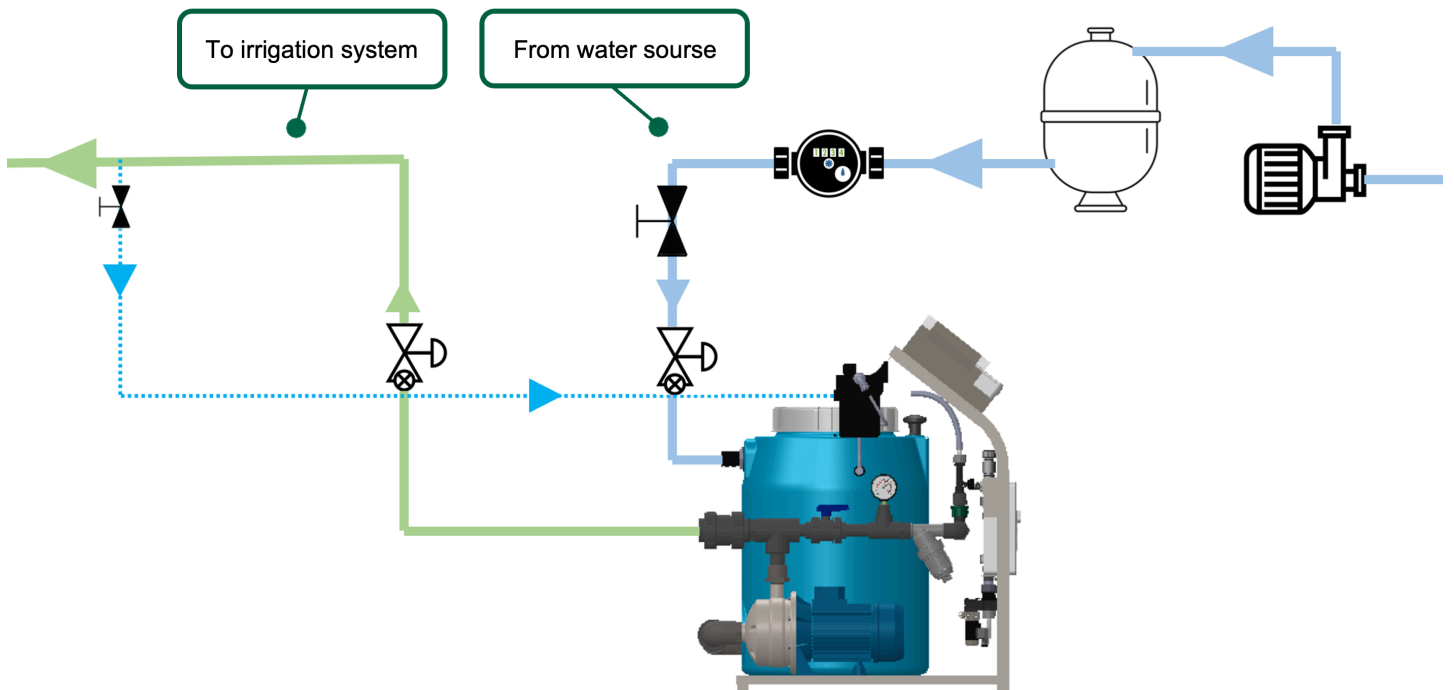

3.1.3 CONNECTION OF EC-PH PROBE HOLDER

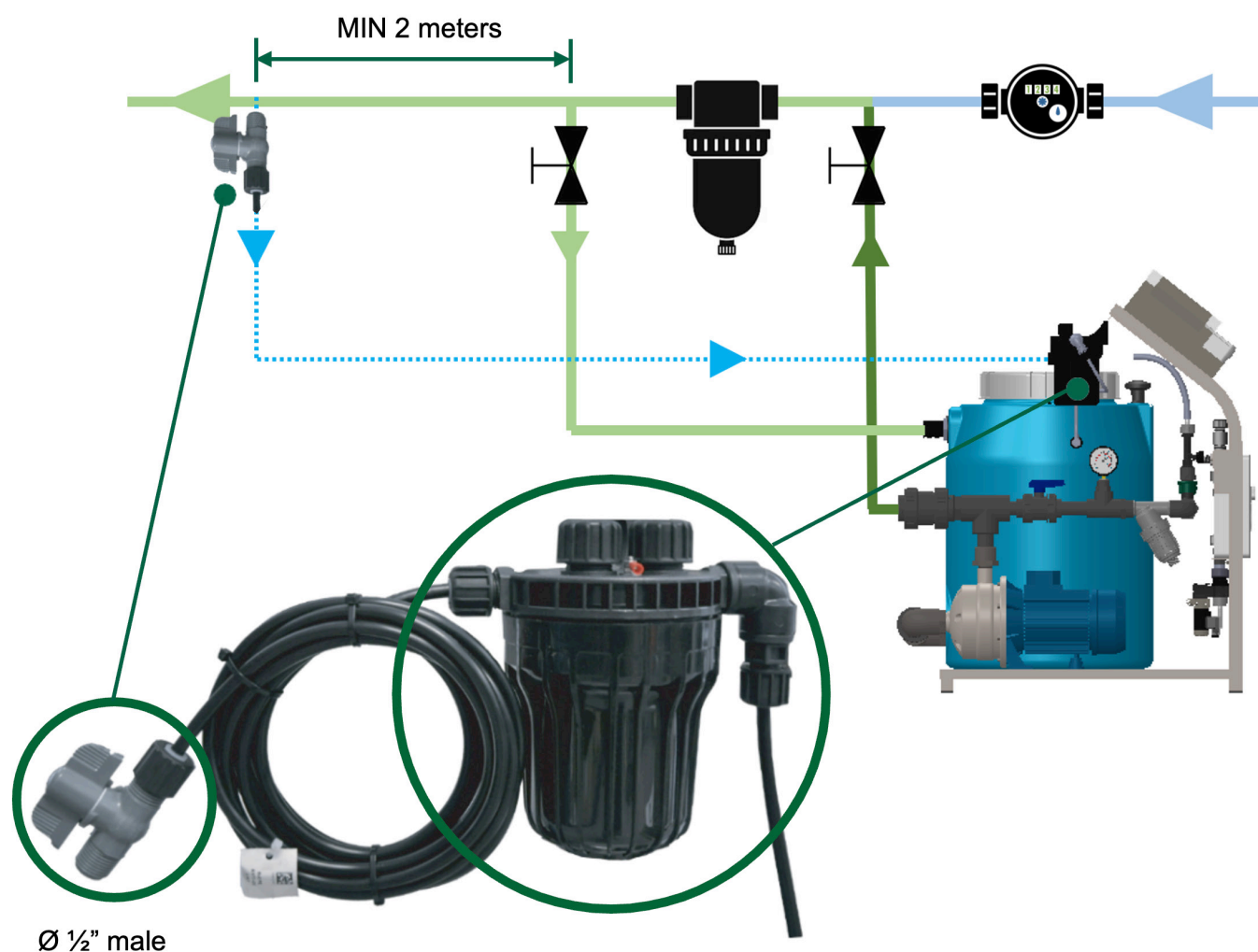

In order to provide the unit with a more regular and correct readings, it is recommended to take the sampling of water from the mainline as far from the unit's connection, as possible, by connecting the inlet pipe of the probe holder at least 2 meters after the unit's inlet.

The outlet of the probe holder is already connected to the premixing tank, therefore preventing any water and fertilizer from being wasted. The probe holder is also equipped with solenoid valve and level switch, which prevents the overflow of the premixing tank through the probe holder.

***Attention**

It is highly important to provide the constant water flow through the probe holder during unit's operation because EC & pH sensors provide correct readings when only being in flowing water, not in the still one. During unit's operation periodically perform the visual check of the flow through the probe holder by opening the premixing tank's cover.

The 1/2" ball valve on probe holder's inlet from the mainline must be always open.

3.1.4 INSTALLATION OF EC&PH SENSORS

Both EC and pH sensors are supplied with Shaker Pro™ already connected to EC-pH Transmitter, but not installed in the probe holder

***Attention**

For the pH sensor it is necessary to keep its electrode constantly immersed in liquid. Ensure that the probe holder is filled with water before installation of the sensor. Keeping the electrode dry for a long time may cause sensor's malfunction.

Unpack the pH sensor from the storage container with liquid and install it in the probe holder in the following order:

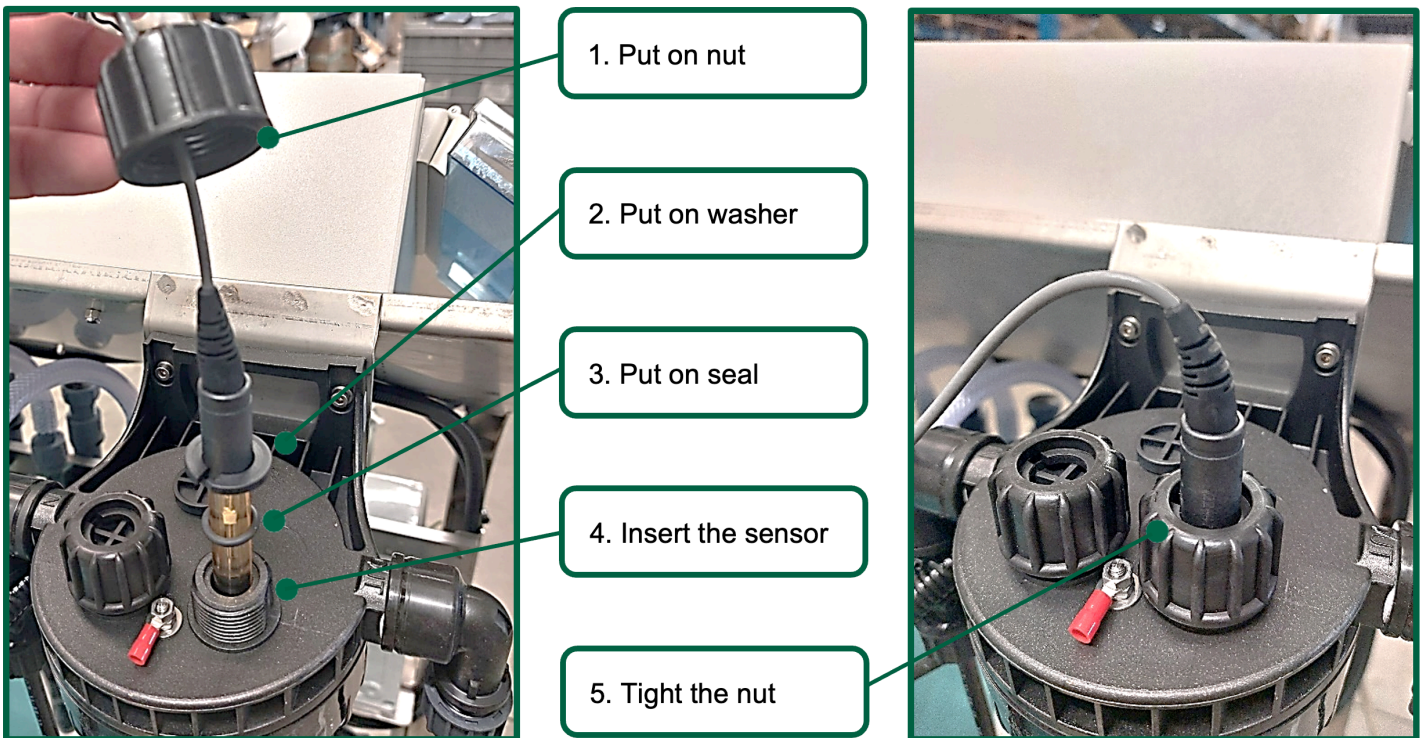

Remove the cover of the EC sensor and repeat the same installation procedure.

3.1.5 CONNECTION OF FERTILIZERS TANKS

- Always use personal protective equipment (PPE) and tools which are suitable for the work being carried out.
- Always use PPE such as gloves and safety glasses when handling fertilizers, acids and other chemicals.
- Ensure nutrient solutions and any acid solutions are available and on site during installation.
- Ensure installation is carried out in such a way as to prevent any possible leakage of fertilizer/acid, as well as to avoid any possible risk of contamination to the environment, soil or surrounding area.
- Install the tanks for fertilizers and acid at the same ground level, as the Shaker Pro™ unit, or higher, but not lower.
- Lowering the tanks relatively to the unit may cause the decrease of injection capacity.
- Ensure that there is sufficient space between the tanks (acid and fertilizer) and the Shaker Pro™ unit for routine management, control and maintenance operations.
- Consult your supervisor or Irritec® technical personnel if any problems are experienced during the installation procedure.
- When using acid (for pH correction), refer to the compatibility notes provided below and always observe the safety instructions of the acid manufacturer.

*Attention

Always install a manual valves and a safety filters on fertilizer tanks and connect them to the Shaker Pro™ unit with non-corrosive pipes (hoses).

Both valves and safety filters must be chemically resistant!

Never use brass valves or fittings for connection of fertilizers and acid tanks!

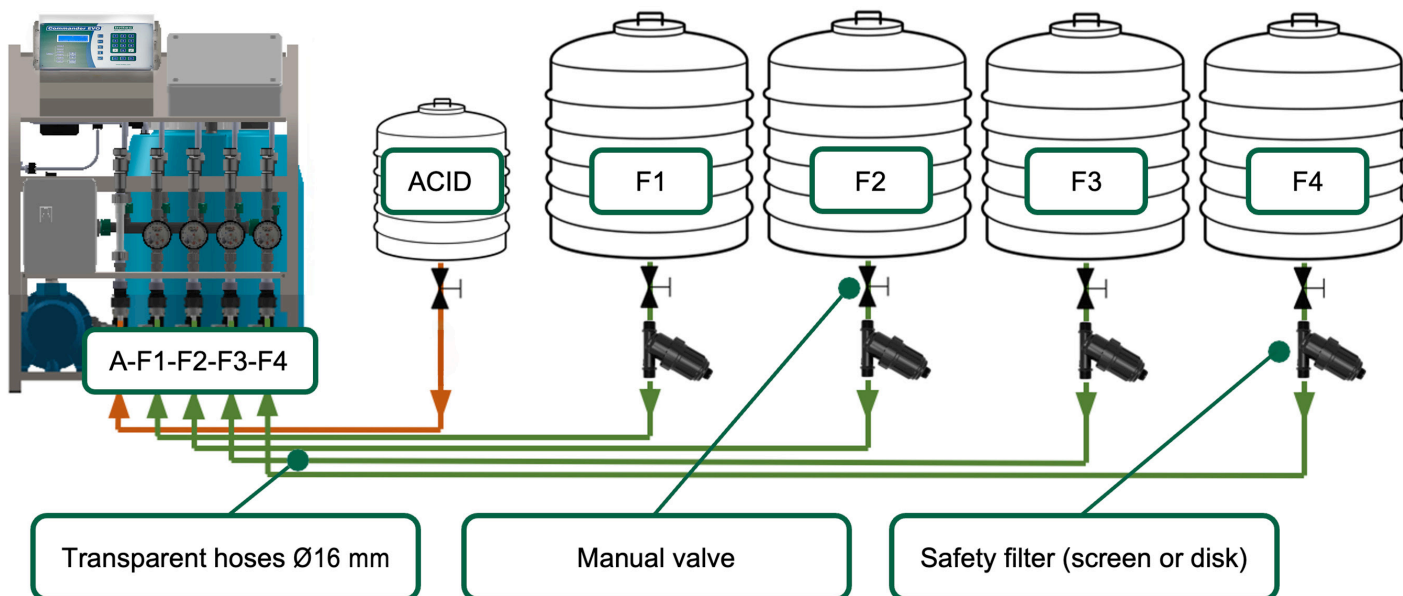

- Connect the tanks to the corresponding suction channels (marked on unit as A, F1, F2, F3, F4) by means of transparent, corrosion-resistant hoses using appropriate hose connectors (Ø16 mm).
- Ensure that acid tank is connected exactly to unit's channel marked "A" ("Acid"). Only this channel is dedicated for acid by means of using sealings made of Viton (FKM/FPM).
- Secure the hose with a clamp (stainless steel, type SS 316, suitable for connecting the fertilizer/acid hose) and record the corresponding valve number on the tank (Acid; F1; F2; F3; F4).



Installation notes:

We recommended braided hoses which are flexible and resistant to stresses during suction and the flow of chemical substances and acids.

Introduce the stainless-steel clamp before connecting the flexible hose (one per flexible hose). If necessary, heat the initial section of the hose in boiling water to facilitate its insertion. Connect the flexible hose of the fertilizer or acid tank to the corresponding **Shaker Pro™** fitting, making sure to leave at least 50 cm (1.7 feet) of hose free. Position the stainless-steel hose clamp on each hose fitting and secure it firmly.

*Attention

There are combinations of fertilizers which, when injected at high concentrations, could cause crystallization in the manifold of the Shaker Pro™ unit, and result in clogging or malfunctions.

Always consult the product suppliers and specify the type of use and application.

FERTILIZERS CAN NOT BE MIXED:

Phosphate with Calcium

Sulphate with Calcium

Magnesium with Phosphates

For acid dosing, use the dedicated dosing channel (marked on the unit) equipped with the appropriate components according to the type and concentration of acid used.

Notes for using acid:

It is strictly recommended not to exceed the following concentrations of acid in tank:

Channel A (Acid) with O-rings and membranes made of Viton (FPM/FKM):

Acid	Concentration, MAX*
HNO ₃	40%
HCL	30%
H ₂ O ₂	50%
H ₂ SO ₄	85%
H ₃ PO ₄	80%

*IN WEIGHT AT 21°C (70°F)

- The table indicates the resistance of the dosing channel components to acids.
- Exceeding the recommended acid concentrations will damage the dosing channels and impair the proper functioning of the unit. The use of chemicals for the treatment and/or control of pests and disease could be corrosive and damage the **Shaker Pro™** fertigation unit.
- For the use of substances other than traditional fertilizers or acids used in fertigation (which do not exceed the concentrations in the table above), always follow the manufacturer's instructions regarding corrosivity, consulting the type of application and method used.

ATTENTION: in order to make a complete assessment of chemical compatibility for actual use and application, full compatibility with the material used to manufacture the valve and other installed accessories (PVC-U, PVC-C, etc.) is also required.

For further information, or in case of doubt, contact your local **irritec®** agent or technician.

3.2 ELECTRICAL CONNECTIONS

*Attention

The following operations must be carried out by an authorised electrician or qualified technician.

ALL CONNECTION OPERATIONS MUST BE CARRIED OUT ONLY WITH THE POWER OFF !

The electrical system must comply with current applicable safety standards and regulations in the country of installation. It is recommended to check the protection provided by the earthing system is $\leq 10 \Omega$.

Install an easily accessible circuit breaker which complies with the total rated power of the Shaker Pro™, as a branch circuit on the current protection in compliance with national codes and standards.

3.2.1 CONNECTION TO THE ELECTRICAL POWER SUPPLY

- Prepare 3 pole thermal-magnetic circuit breaker C16A as a branch circuit for Shaker Pro™ unit.
- Check if the main power switch selector on the electric panel of the Shaker Pro™ is in "O" (OFF) position.
- Open the electric panel with the aid of a screwdriver.
- Connect the power supply (three phases and neutral) to the unit's main power switch terminals as shown below.
- Connect the ground to the corresponding terminal as shown.
- Close the electric panel and ensure that main power switch selector fits its position.

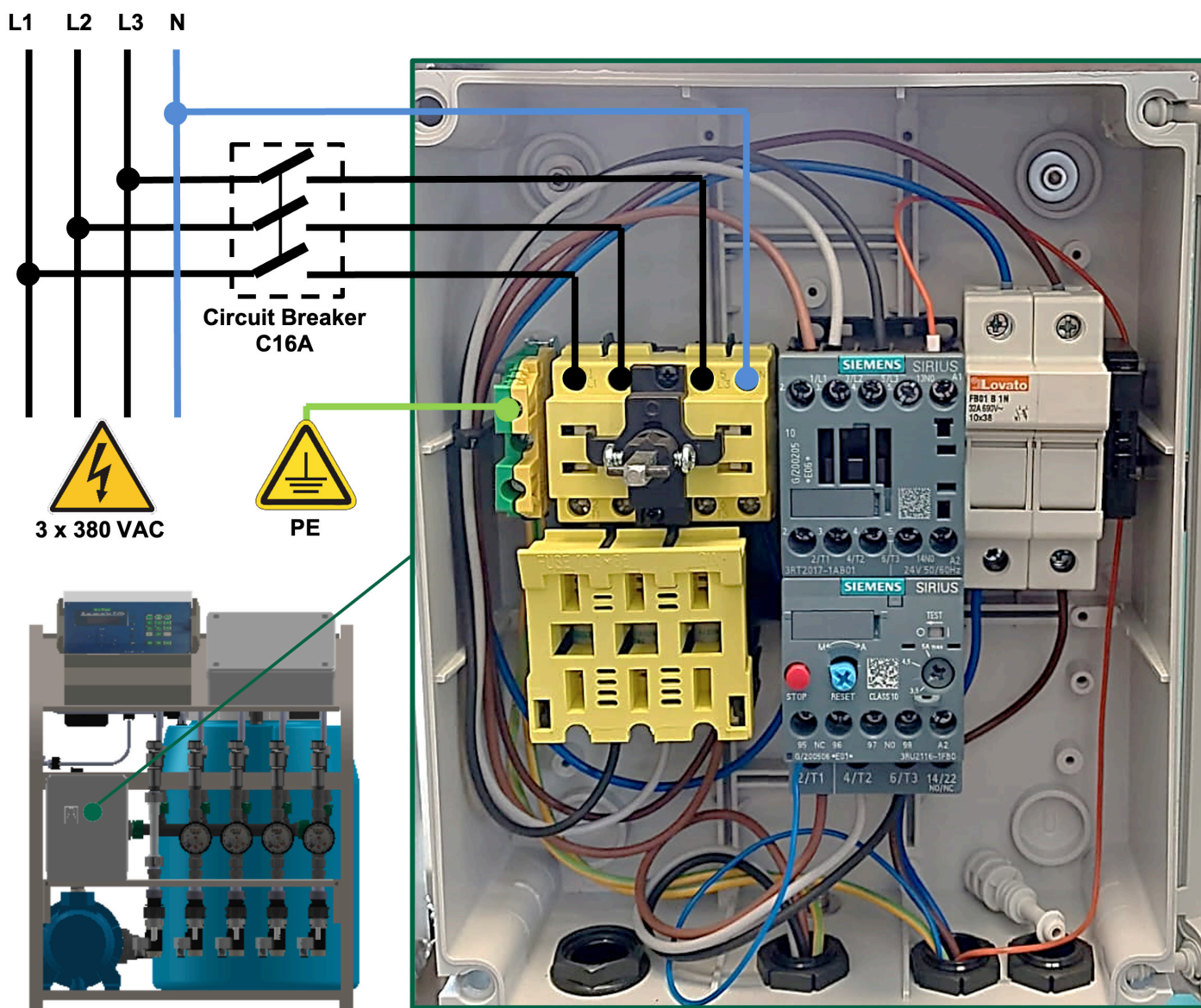

3.2.2 CONNECTION OF MAIN IRRIGATION PUMP

All the peripheral devices, such as main irrigation pump, water meter, irrigation valves, mixer etc., must be electrically connected to the corresponding terminals inside the connection box of the **Shaker Pro™** unit.

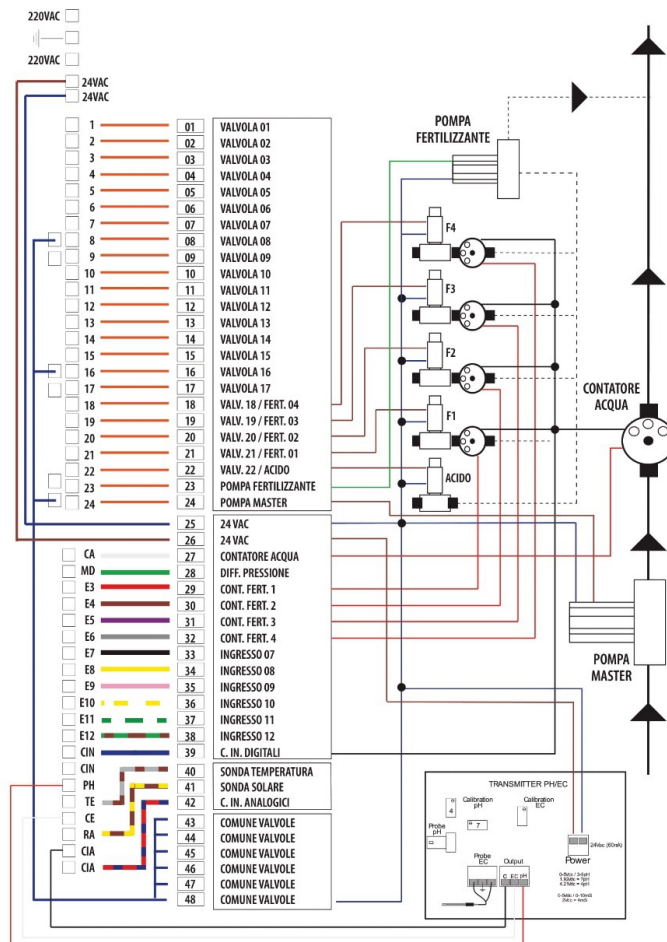
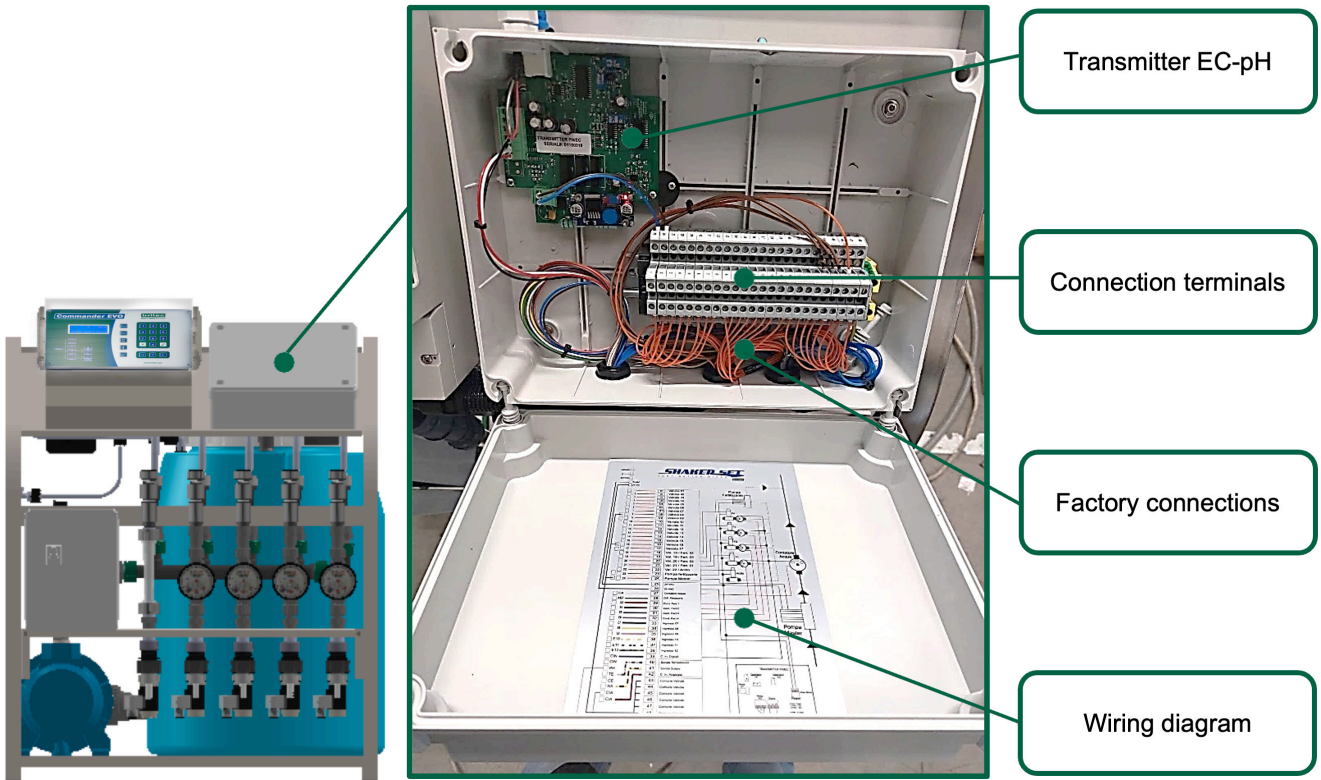

***Attention**

Ensure that there is no electrical power both on Shaker Pro™ unit and pump control panel before connecting the pump.

All **Shaker Pro™** control outputs are 24 Vac, therefore a relay with corresponding coil voltage is needed to control the main irrigation pump. Connect pump's relay to the terminals as follows:

24 – pump's output ~24 Vac (preset, refer to **Commander EVO® Gold** programming manual)

48 – common ~24 Vac

NOTE: the relay is not included in the supply.

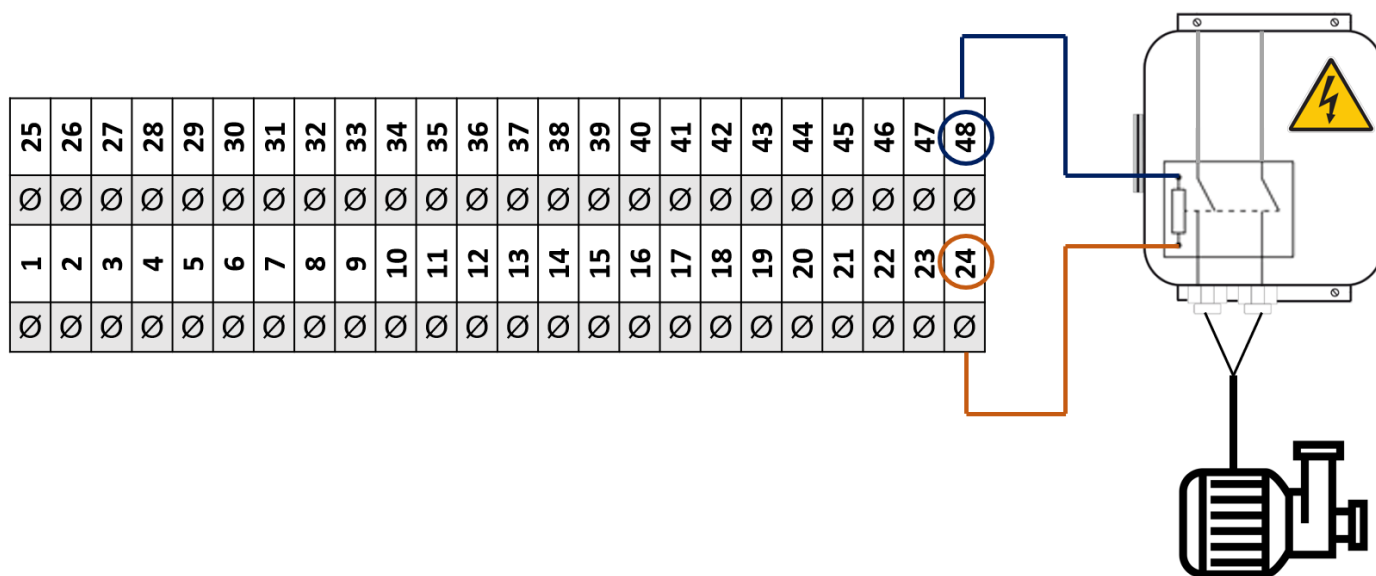

3.2.3 CONNECTION OF SYSTEM WATER METER

Shaker Pro™ can register only one main water meter with magnetic pulse emitter (“dry contact” Reed switch with 1 pulse per 1, 10, 100 or 1000 liters). Connect the water meter to the terminals as follows (polarity is not important):

27 – water meter’s digital input (this is dedicated controller’s input for meter, which cannot be changed)

39 – common input

If you have a pulse emitter different from the Reed switch – please contact your local **Irritec®** agent or technician.

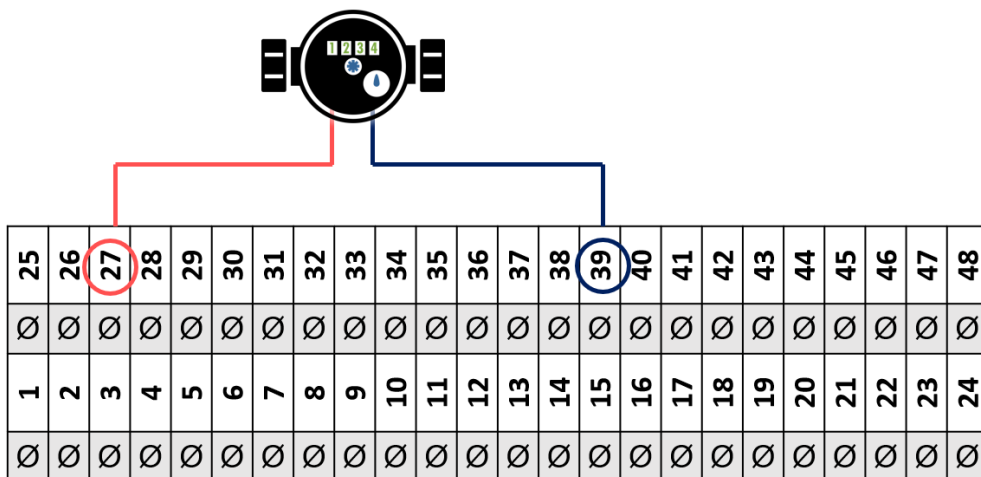

Connection terminals

IMPORTANT: after connecting the water meter and before starting irrigation/fertigation program it is necessary to configure the water meter parameters (measurement units and pulse value) in the **Commander EVO® Gold** controller. Please refer to the controller’s manual before starting the system.

3.2.4 CONNECTION OF IRRIGATION VALVES

Depending on configuration of dosing channels, **Shaker Pro™** control unit has from 17 to 19 outputs ~ 24 Vac, which can be used for irrigation valves control, managing of auxiliary pumps and fertigation mixer. By default, all these outputs are configured in controller as irrigation valves, for connection and configuration of auxiliary pumps and fertigation mixer please refer to **Commander EVO® Gold** programming manual.

***Attention**

Ensure that Shaker Pro™ unit is powered off before connecting the devices.

Connect irrigation valves' solenoids to the terminals as follows (polarity of solenoid's wires is not important):

- Valve 1: output 1 + common on 43...48
- Valve 2: output 2 + common on 43...48
- Valve 3: output 3 + common on 43...48
- ...
- Valve 17: output 17 + common on 43...48

NOTE: output's number is already a valve's number in irrigation/fertigation program, no need to configure valves in controller.

For any doubts refer to **Commander EVO® Gold** manual.

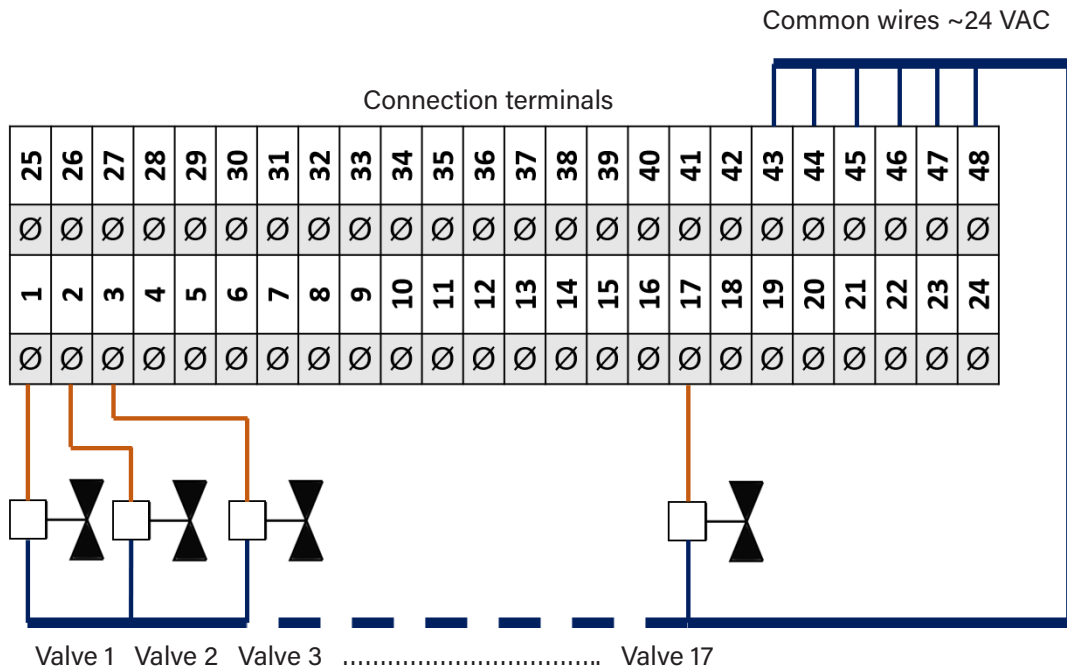

NOTE: if there are more irrigation valves than Shaker Pro™ outputs available, the number of outputs can be easily extended by adding **CEE** wired extension of 16 or 24 outputs ~24 VAC. Contact your local Irritec® agent for ordering if needed. For the connection of extensions please refer to Commander EVO® Gold manual and dedicated section of this manual.

3.2.5 CONNECTION OF SOLAR RADIATION SENSOR

Shaker Pro™ can register the readings of SS5 solar radiation sensor, thus automatically adjusting irrigation frequency depending on accumulated solar radiation in W/m². Please refer to **Commander EVO® Gold** programming manual for irrigation by radiation settings.



NOTE: the sensor is not included in the supply and can be ordered separately, contact your local **Irritec®** agent if needed.

***Attention**

Ensure that Shaker Pro™ unit is powered off before connecting the sensor.

It is strongly recommended to install the solar radiation sensor no further than 15 meters from Shaker Pro™ unit, with a cable at least 1.5mm² cross section.

Voltage drop due to using of longer cable or a smaller cross section may cause a malfunction of controller's analogic input.

Connect the sensor to the terminals as follows (**polarity is important**):

- 25 – sensor's power ~24 Vac
- 26 – sensor's power ~24 Vac
- 41 – analogic input +5 Vdc
- 42 – analogic input common -

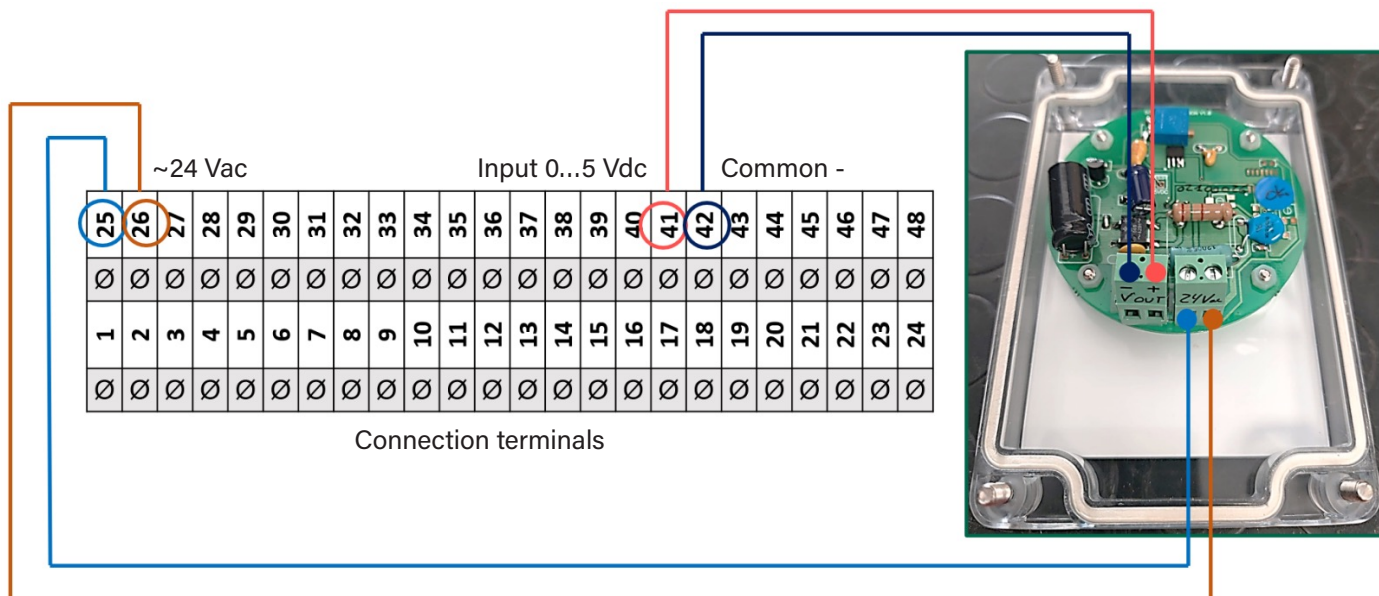

3.2.6 CONNECTION OF MODEM, WIRED EXTENSIONS AND RADIO TRANSMITTER

The connections of peripheral devices such as GPRS/Wi-Fi modem, CEE extension units or CER radio transmitter for EVO® Radio system are made not in the connection box of **Shaker Pro™**, but directly inside the Commander EVO® Gold controller.

***Attention**
Ensure that **Shaker Pro™** unit is powered off before connecting the devices.

Open the lower panel of Commander EVO® Gold controller with the aid of a screwdriver:

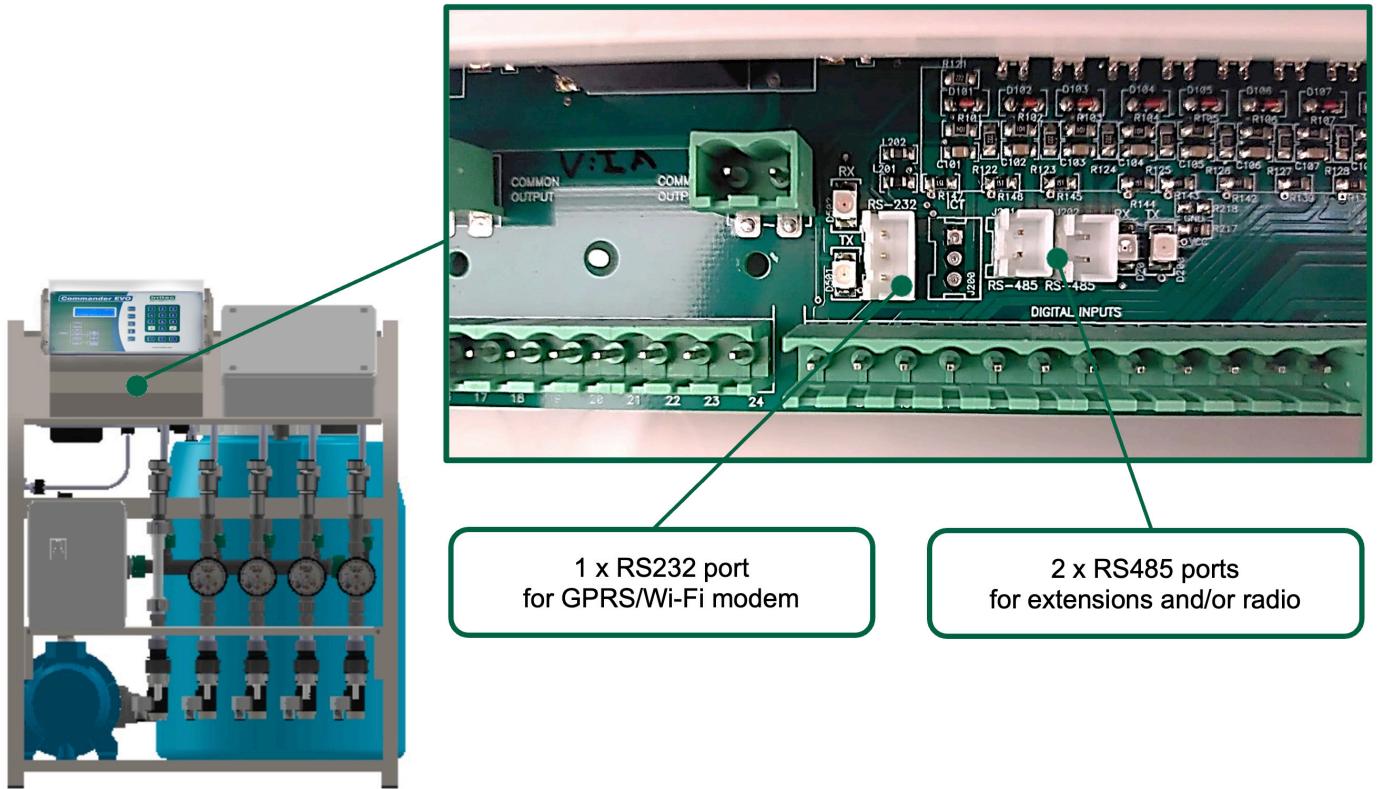

1 x RS232 port
for GPRS/Wi-Fi modem

2 x RS485 ports
for extensions and/or radio

CONNECTION OF GPRS/Wi-Fi MODEM: connect the modem to controller's RS232 port with provided communication cable (supplied with modem). Each modem is supplied fully configured for the needed type of connectivity, no need to make any settings in the **Commander EVO® Gold** controller.

NOTE: the modem is not included in the supply and can be ordered separately, contact your local **irritec®** agent if needed.



RS232 communication cable

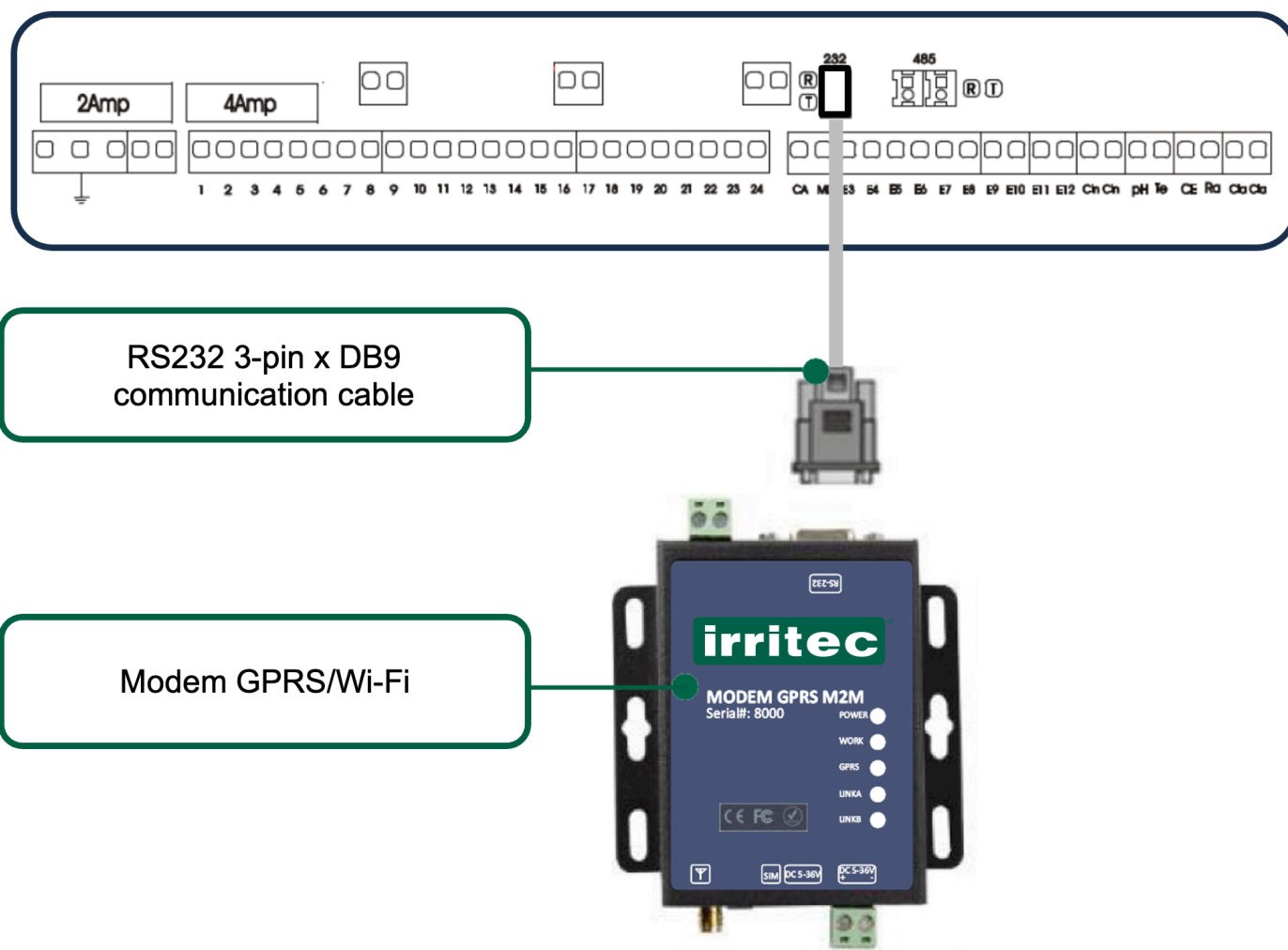

RS232 3-pin x DB9 communication cable

Modem GPRS/Wi-Fi

User's credentials, provided with modem, can be used for access to **Farmonitor** remote control software <https://irritec.farmonitor.com/>



CONNECTION OF CEE EXTENSIONS: connect the **CEE** extensions to the Commander EVO® Gold with the supplied RS485 2-pin cable on any of 2 RS485 ports. If you have more than one extension – they must be connected in parallel with similar RS485 cables.

IMPORTANT: for the correct wiring of extensions and controller's settings please refer to Commander EVO® Gold and CEE extension manuals. It is necessary to set **"Expansions: Ys"** in **"Configuration"->"Irrigation"** menu of Commander EVO® Gold. All irrigation valves, connected to the extensions, will have numbers starting from 100: 101, 102, ...196.

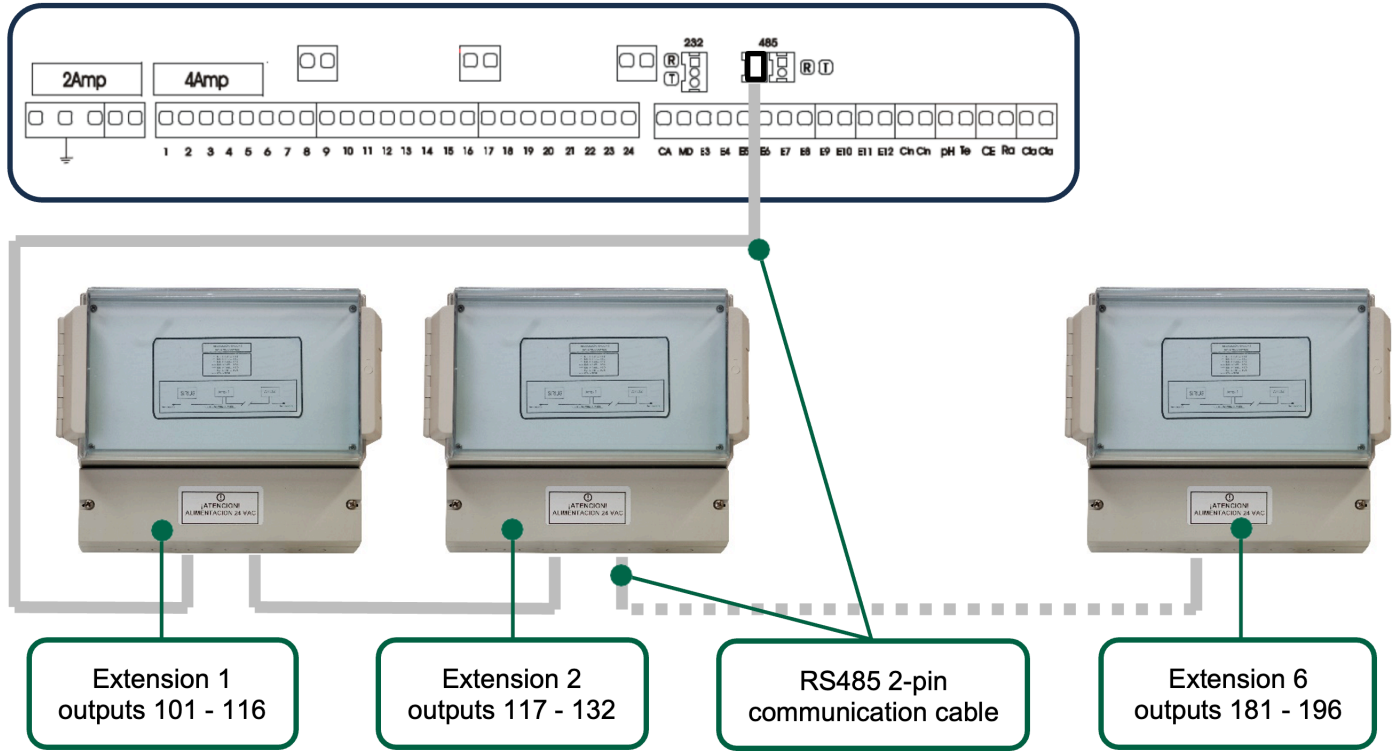

CONNECTION OF RADIO TRANSMITTER: connect the **ICT25** radio transmitter to the Commander EVO® Gold with the supplied RS485 2-pin cable (same as for extensions) on any of 2 RS485 ports.

IMPORTANT: for the correct wiring of radio transmitter and controller's settings please refer to Commander EVO® Gold and EVO® Radio system manuals. It is necessary to set **"Radio: 200"** in **"Configuration"->"Irrigation"** menu of Commander EVO® Gold. All irrigation valves, connected to the extensions, will have numbers starting from 200: 201, 202, ...296.

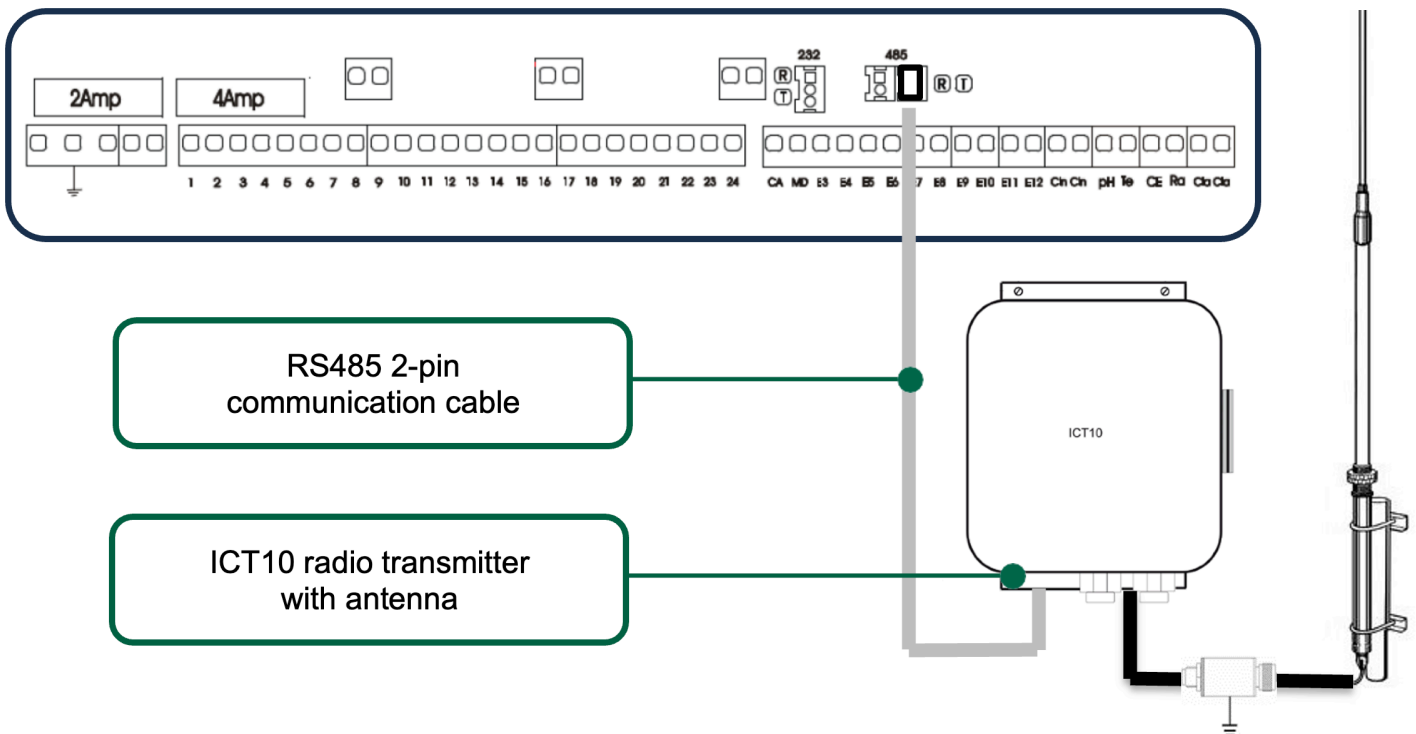

4 START-UP AND ADJUSTMENT

4.1 OPENING THE HYDRAULIC CIRCUIT

- 1) Start the pump and pressurize the system.
- 2) Wait until the required irrigation system pressure is achieved. Check the flow meter and all pressure gauges, and ensure that all hydraulic conditions are within the range (pressure and flow) rated for the system.
- 3) Gradually open the bypass valve installed at the inlet of Shaker Set™ and fill the premixing tank, until the float valve inside the tank will automatically close the filling.
- 4) Gradually open the bypass valve installed at the outlet of Shaker Pro™.
- 5) Gradually open the ball valve of the probe holder.
- 6) Keep the system under working pressure for at least 10 minutes and visually check for any leaks.

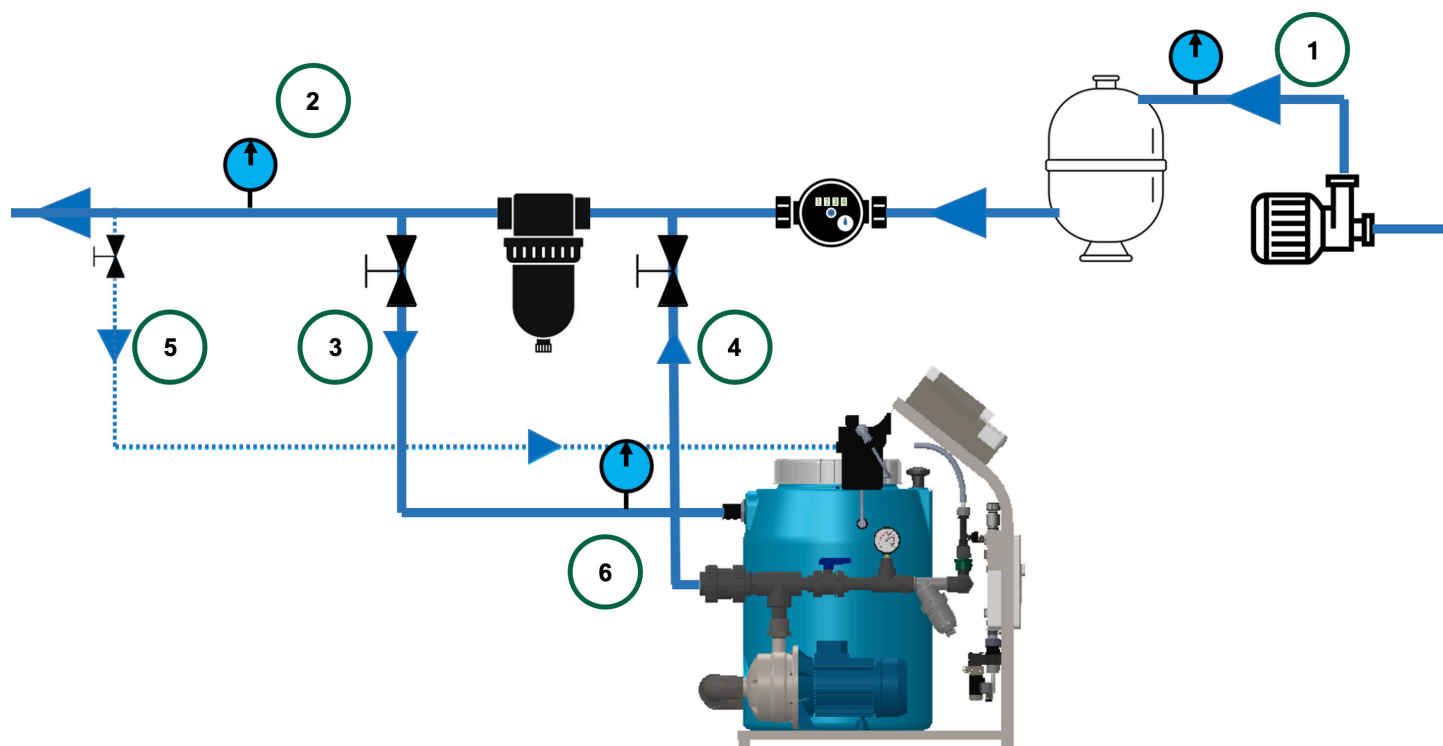

4.2 CHECKING OPERATION AND DIRECTION OF PUMP ROTATION

***Attention**

Ensure that the hydraulic circuit (see above) and the by-pass valves have been opened before starting the unit's pump.

Read the Commander EVO® Gold manual carefully before starting the unit.

- 7) Ensure that all the fertilizer valves on tanks are closed.
- 8) Turn ON the power switch on a unit's main power panel, wait until the Commander EVO® Gold is fully downloaded.



- 9) From the "Manual activation" menu of the Commander EVO® Gold controller start the unit's pump by activating the output 23.



- 10) Check if the pump is rotating in the correct direction (clockwise). If the direction is incorrect – switch OFF the power and swap 2 of 3 phase wires of the power supply.

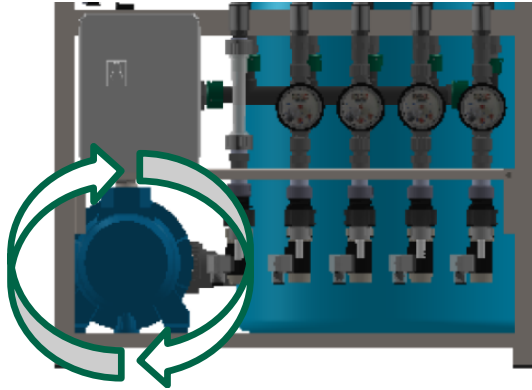

- 11) Open the cover of the premixing tank and check that the water level inside the tank is stable during circulation. Check that there is a homogenous flow from Venturi's outlets inside tank. Adjust bypass valves if needed to achieve the stable water level inside the tank.



- 12) Check the pressure inside the unit with the installed pressure gauge. Optimal working pressure is between 3 and 6 bar. Adjust bypass valves if needed to achieve the optimal pressure.

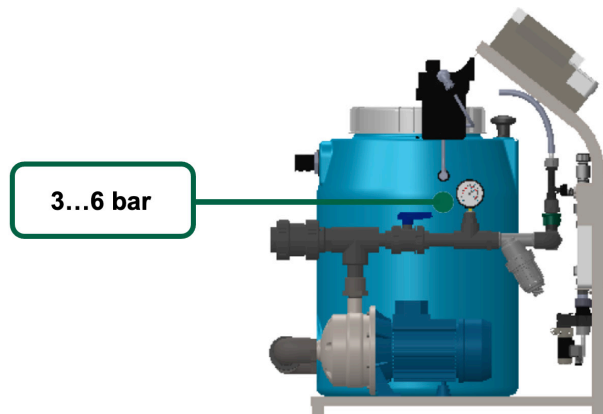

- 13) Keep the Shaker Pro™ unit working in this mode for at least 10 minutes. Check if the water level in the premixing tank is still stable and visually check for any leaks.

4.3 CHECKING OPERATION, TESTING AND ADJUSTING OF SUCTION AND INJECTION CHANNELS

IMPORTANT: for testing and adjustment operations it is recommended to fill the fertilizer tanks with water, at least during the first step.

- 14) Ensure that fertilizers tanks are filled with water for test.
- 15) Temporarily deactivate all controller's alarms for EC/pH, flow control etc. (see Commander EVO® Gold manual).
- 16) Check if the unit's dosing valves are in CLOSE position:

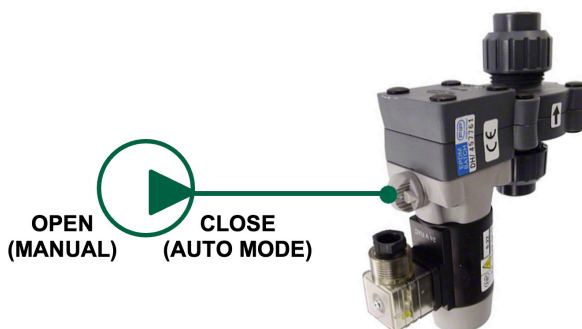

- 17) Gradually open the manual valves from each fertilizer tank, visually check for any leaks.

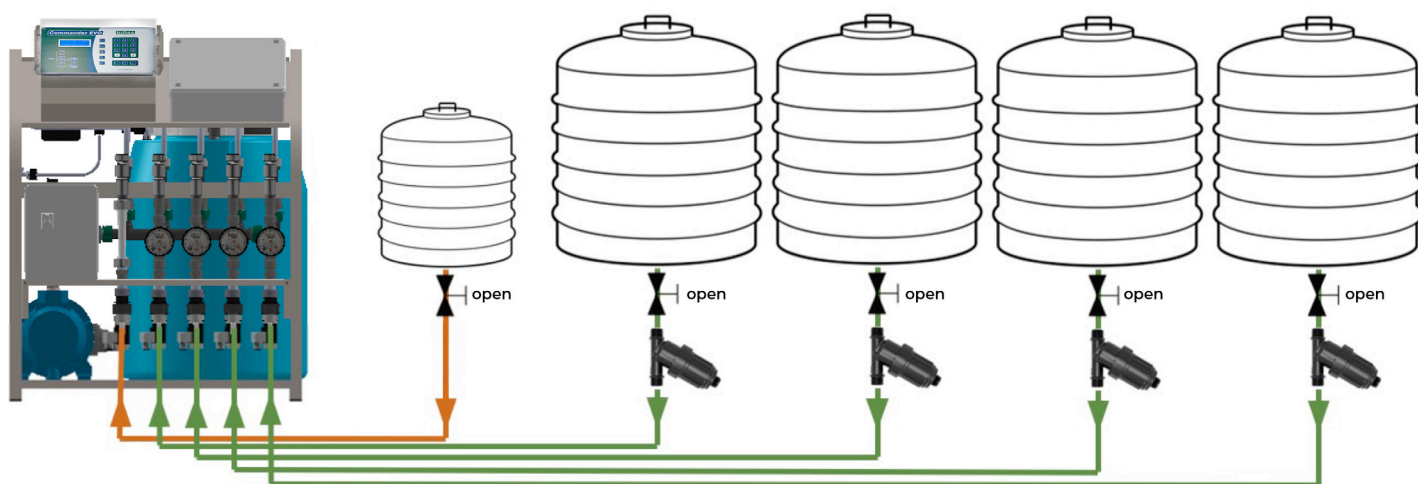

- 18) From the "**Manual activation**" menu of the Commander EVO® Gold controller start each dosing channel as follows:
 - Output 22 – Acid (A)
 - Output 21 – Fertilizer 1 (F1)
 - Output 20 – Fertilizer 2 (F2)
 - Output 19 – Fertilizer 3 (F3)
 - Output 18 – Fertilizer 4 (F4)

After starting each output, the corresponding dosing valve's LED should be lit and "click" should be heard.

NOTE: unit's pump must be still working while testing the dosing channels.



- 19) Visually check the flow through Acid dosing channel by monitoring the glass flowmeter. Visually check the flow through F1 – F4 dosing channels by monitoring the fertilizer meters' rotation. If there is no flow through one or several channels – refer to the TROUBLESHOOTING section of this manual.

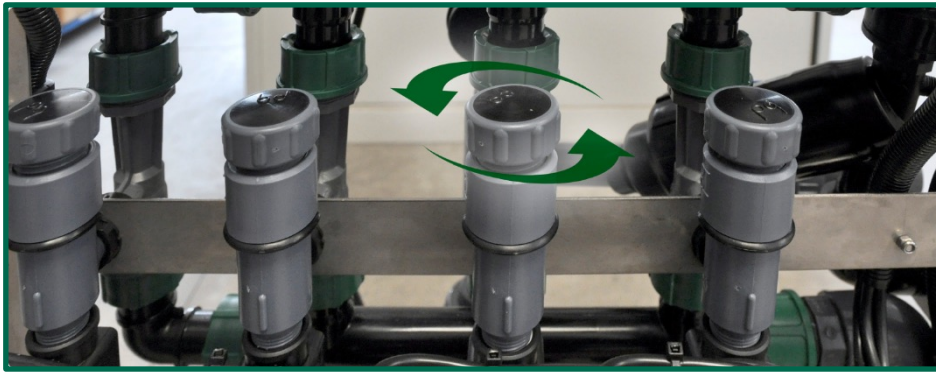
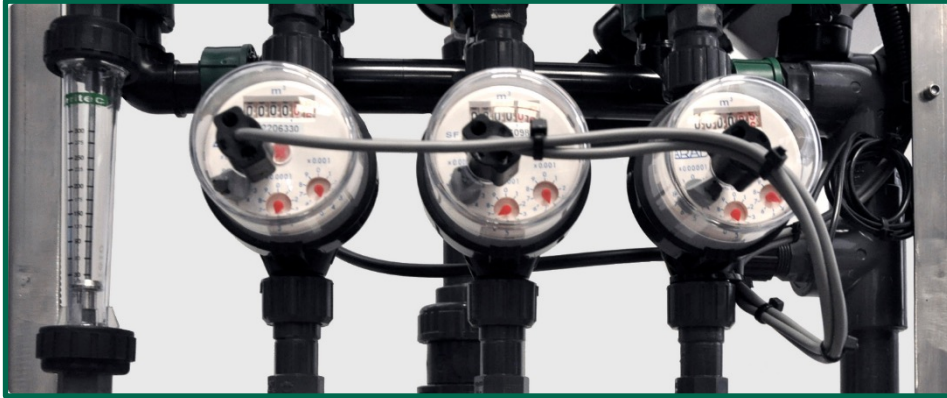

- 20) Adjust the flow through Acid dosing channel by using the corresponding needle valve so that the float of the glass flowmeter was at the upper end of the scale (300 l/h), but not higher. Adjust the needle valves of the F1 – F4 dosing channels approximately at a same level, as for acid channel (opened for 80-90%).

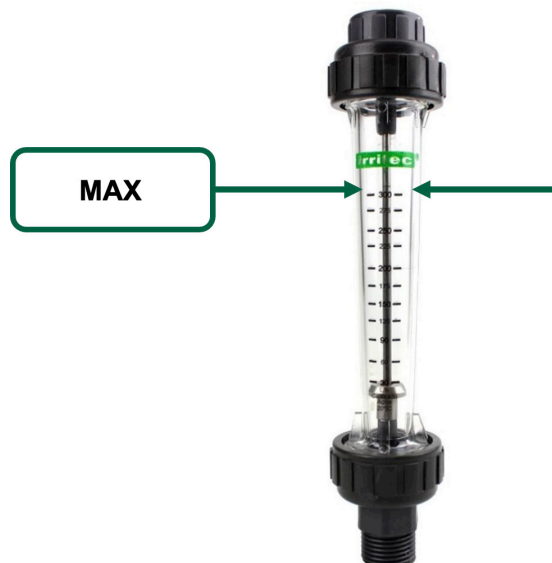

- 21) Let the system run for at least ten minutes and check that everything is working properly and that there are no leaks from dosing and suction channels, and no air bubbles from Venturi's outlets to the premixing tank.

4.4 CALIBRATING THE PROBES

Shaker Pro™ fertigation unit is supplied with both EC & pH factory calibrated. However, it is strongly recommended to calibrate them again after installation on site and before commissioning the system.

*Attention

Turn OFF Shaker Pro™ unit's pump, unpressurize the hydraulic circuit and close the by-pass valves, as well as the probe holder valve, before starting the probes' calibration.

From the **"Manual deactivation"** menu of the Commander EVO® Gold controller stop the unit's pump and all the dosing channels (see the Commander EVO® Gold manual). The controller itself must be ON during calibration.

Open the Shaker Pro™ connection box to access the EC-pH Transmitter board.

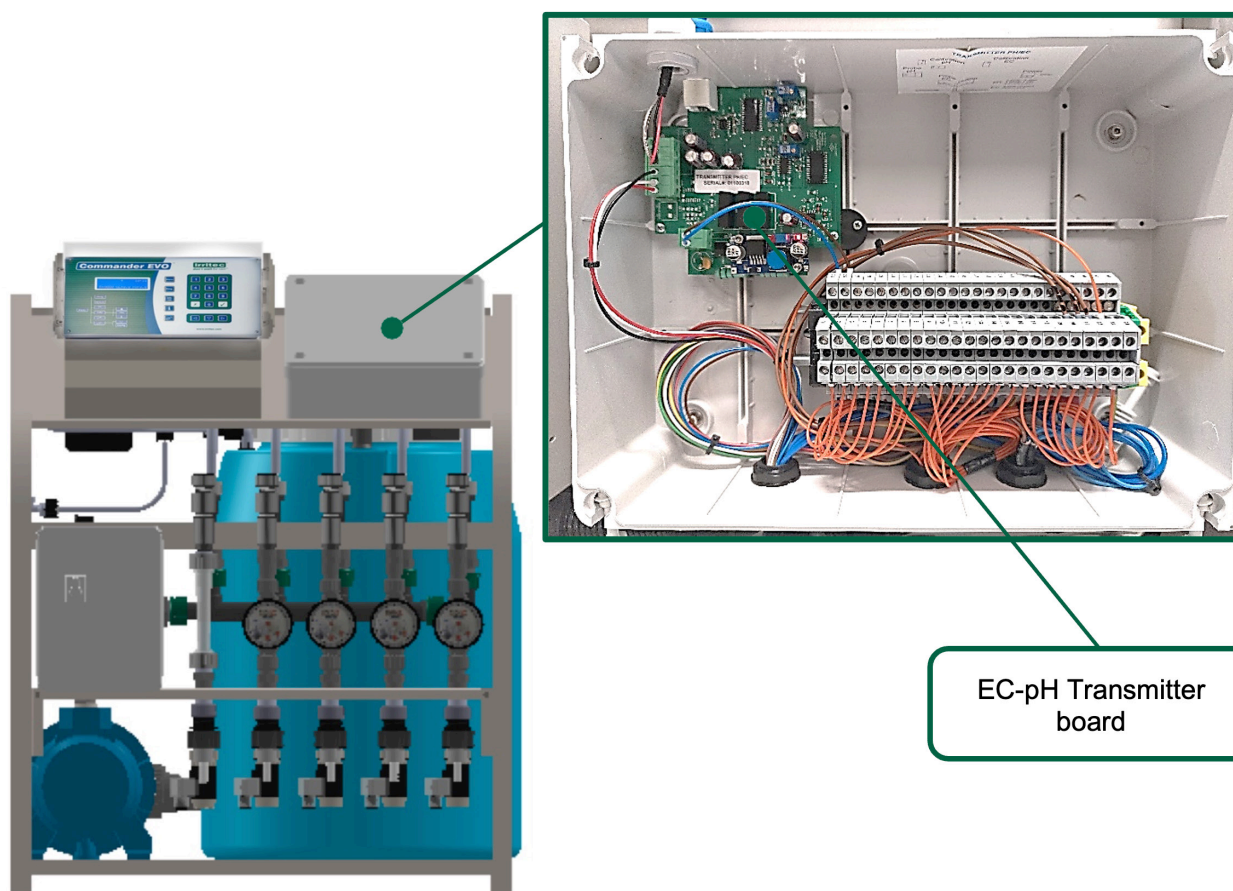

Prepare the calibration solutions: pH 7, pH 4 and EC 1413 $\mu\text{S/cm}$.

NOTE: calibration solutions are not included in supply and can be ordered separately or purchased in the local laboratory, contact your local **Irritec**® agent if needed.



Calibrating pH

- 1) Extract the pH probe from the probe holder.
- 2) Rinse the electrode and immerse it in the pH 7.01 standard solution.
- 3) With the aid of a screwdriver adjust the potentiometer marked "PH7" on the EC-pH transmitter board until you will see "pH: 7.0" at the Commander EVO® Gold main screen.

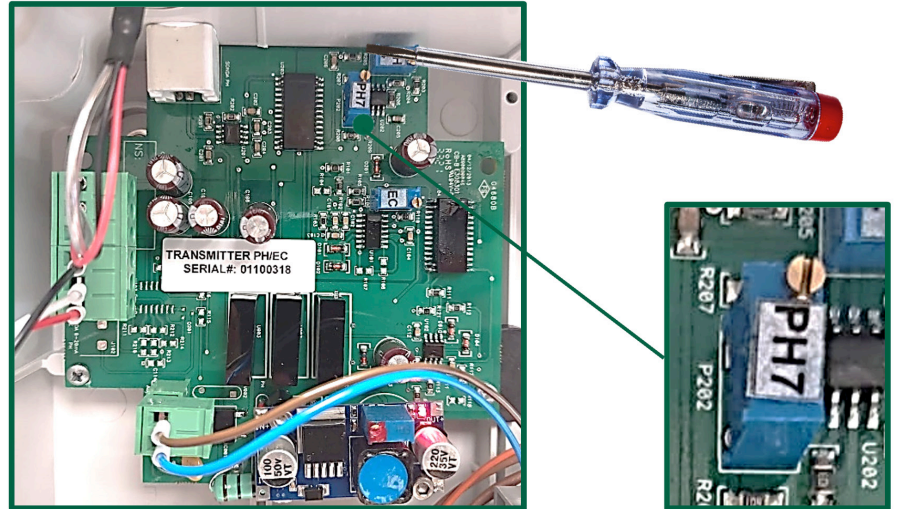

- 4) Rinse the electrode and immerse it in the pH 4.01 standard solution.
- 5) With the aid of a screwdriver adjust the potentiometer marked "PH4" on the EC-pH transmitter board until you will see "pH: 4.0" at the Commander EVO® Gold main screen.

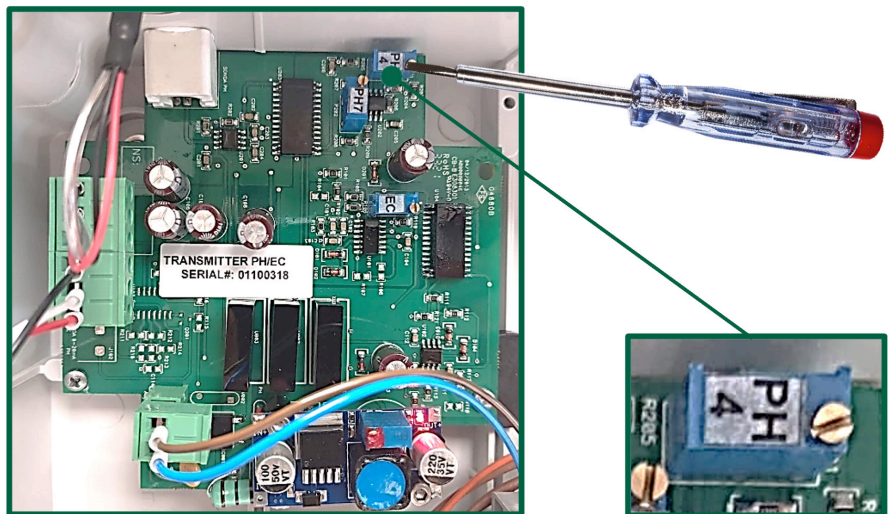

- 6) Rinse the electrode and install the pH probe back to the probe holder.

Maintenance of the pH probe

When the probe is not in use, rinse the electrode with tap water and store it with a few drops of pH 7.01 solution in the cap of the protective container.

For proper storage of the pH probe, never use distilled or deionized water.

If the probe's electrode is dry, leave the probe to soak in a 7.01 pH solution for at least one hour before reassembling it and reactivating it. To prevent porosity obstructions, it is recommended to clean the electrode at least once a month.

Calibrating EC

- 1) Extract the EC probe from the probe holder.
- 2) Fully immerse the EC probe in the standard solution 1413 $\mu\text{S}/\text{cm}$ (other solution can be used if you know precisely its value in $\mu\text{S}/\text{cm}$).
- 3) With the aid of a screwdriver adjust the potentiometer marked "EC" on the EC-pH transmitter board until you will see "EC: 1.4" at the Commander EVO® Gold main screen.

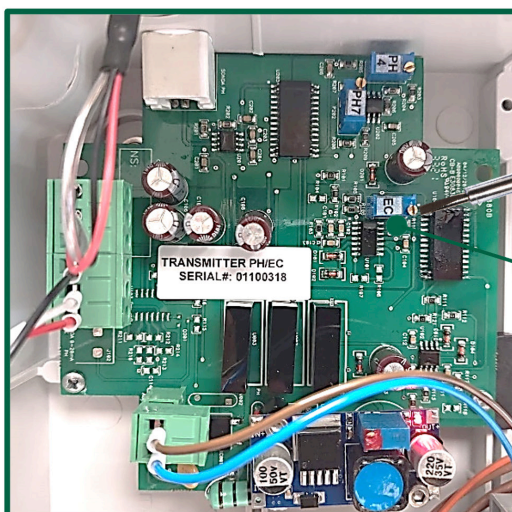

- 4) Install the EC probe back to the probe holder.

Maintenance of the EC Probe

Remove the probe and rinse it with tap water when not in use.

4.5 ADJUSTING THE UNIT

After connecting all the devices and testing the operation, it is necessary to make initial settings in the **Commander EVO® Gold** controller for the proper operation of **Shaker Pro™** fertigation unit.

*Attention

Read the **Commander EVO® Gold** manual carefully before adjusting the unit.

General settings

In the **"Settings"** -> **"Irrigation"** menu set the following:

"Expansions : Ys" – if you have wired extensions connected.

"Radio group: 200" – if you have EVO® Radio system connected.



Defining system water meter

If you have main water meter connected to the unit, in the **"Settings"** -> **"Flowmeters"** menu set its measuring units and pulse constant:



Defining general fertigation mode

It is necessary to set the needed fertigation mode for the unit before making irrigation and fertigation programming.

IMPORTANT: this parameter is global and affects fertigation parameters of all irrigation blocks and programs. Only one fertigation mode can be selected.

There are 3 modes of fertigation in the **"Settings"** -> **"Fertilization"** menu:



"0 = Time/Volume": fertigation by time or volume of fertilizers. Value for each injector can be set in **"Blocks"** menu for each irrigation valve or group of valves.

"1 = EC Control": all injectors will operate to maintain the EC value in certain proportions. The EC setpoint and proportion for the injectors can be set in **"Blocks"** menu for each irrigation valve or group of valves.

"2 = Volume/Proportion": fertigation by volume of each fertilizer or proportionally to the water flow (liters per m³). Value for each injector can be set in **"Blocks"** menu for each irrigation valve or group of valves.

Fertigation mode can be changed at any time if necessary.

Adjusting pH & EC control parameters for precise dosing

If the EC control mode is selected, it is necessary to adjust the Shaker Pro™ fertigation unit for the precise maintenance of the EC and pH setpoints, entered by user.

*Attention

It is always necessary to adjust EC & pH control parameters, such as "Delay in Control" and "Initial Dosing Speed" for each specific irrigation system before commissioning the Shaker Pro™ fertigation unit.

There is an important parameter in the **"Settings"** -> **"Fertilization"** menu to be defined experimentally for each hydraulic system with Shaker Pro™ installed – EC and pH control delay. This is the delay in seconds between sampling the current EC and pH values and reaction of the controller by means of changing the dosing speed to reach the desired setpoint. This delay also allows the fertilizers and acid to be properly diluted in the irrigation water for the precise dosing and reasonable use of chemicals.



For example, delay of 5 seconds (default setting) means that each 5 seconds controller will automatically adjust the dosing speed depending on delta between the actual measured value of EC and pH and the setpoints, defined by user. The bigger is delta – the more dosing speed will be increased (or decreased).

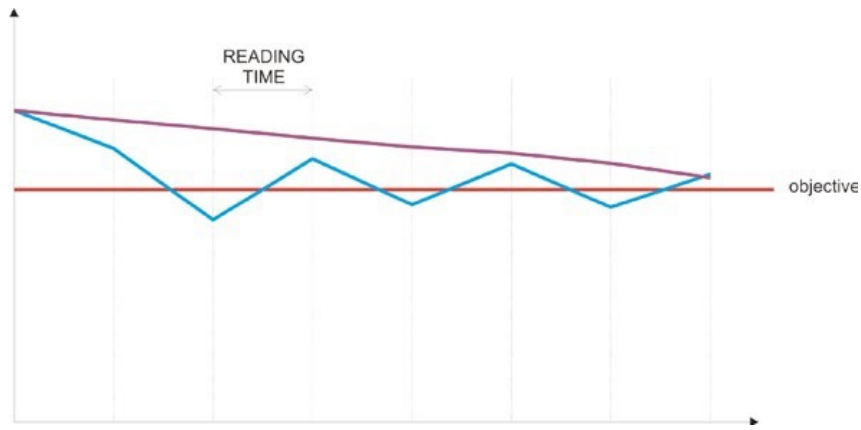

If the actual measured value of pH or EC is "jumping" around the setpoint or overcome it, this means that the delay time is too long and must be decreased. In opposite, if there is too much time needed to reach the setpoint after starting the irrigation – the delay time must be increased.

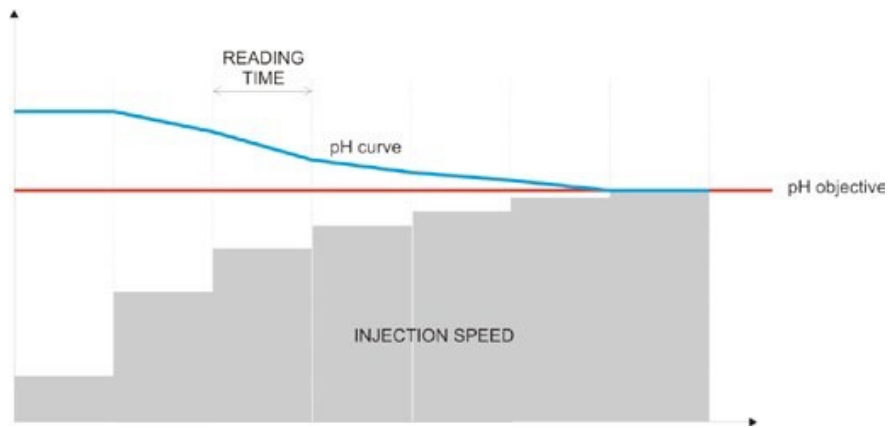

Another solution to reach the setpoint in a short time is to increase the Initial Dosing Speed for the specific irrigation block. This option is useful when short irrigation cycles are programmed.

To define the needed Initial Dosing Speed, start the irrigation block, wait until the setpoint will be reached (1), check the actual speed in the Commander EVO® Gold "Info" menu (2) and set this value in % as Initial for this block (3). After this the block will start with higher dosing speed (4) and reach the setpoint faster.

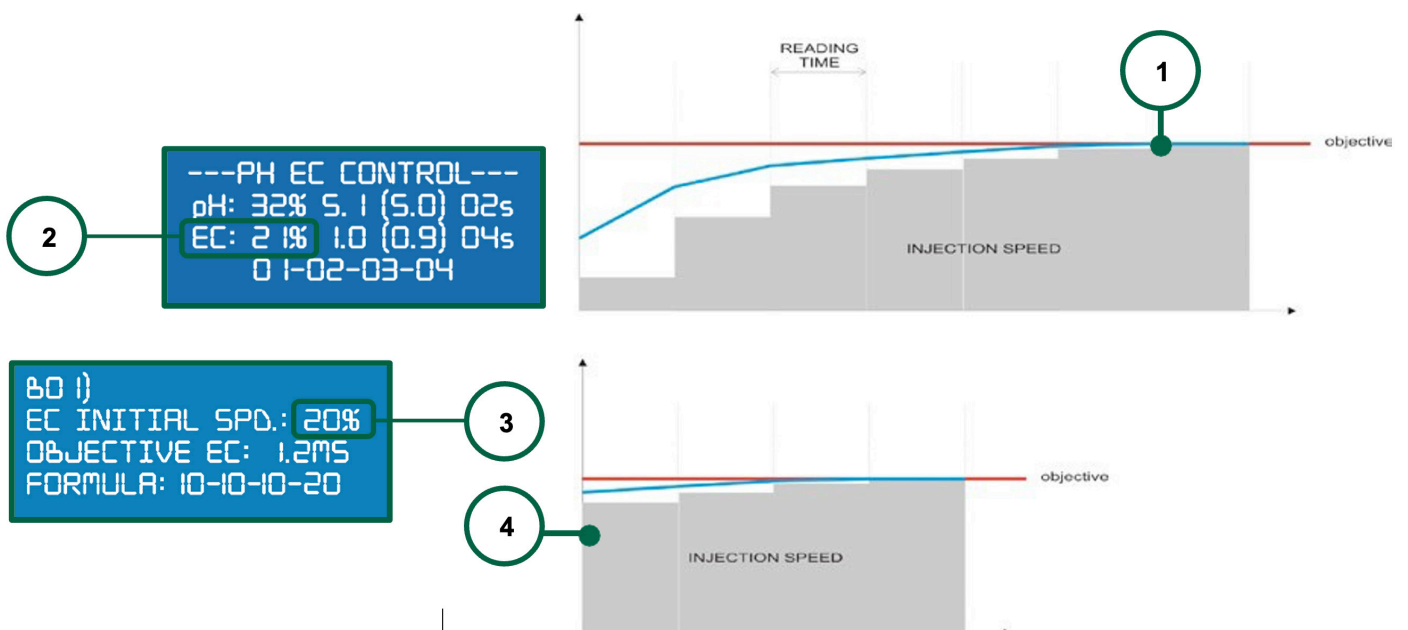

EC formula

If the EC control mode is selected, it is necessary to define the relation between the dosing channels in the EC setpoint maintenance. This formula can be set for each irrigation block. If the value for the injector is set 00 – it will not participate in EC control for this irrigation block:



For example, formula 20-10-10-00 means that injection channel F1 will be always dosing twice more than channels F2 and F3, and the F4 channel will be always closed. Depending on delta between the actual EC value and the setpoint, the dosing speed will be changing automatically, but always keeping the set proportion:

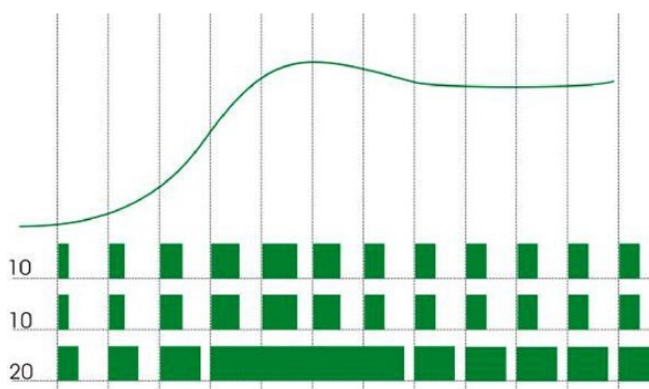

Formula 20-10-10-00 will work the same way, as formula 02-01-01-00 or 60-30-30-00 or 06-03-03-00. Only the relation between the dosing channels is important.

Checking the concentration of fertilizers/acid

If the Shaker Pro™ is used to operate in EC control mode, it is recommended to first check the correctness of the prepared formula so that the machine can work within an adjustment range of $\pm 30\%$ deviation from the target values.

To accomplish this, it is recommended to carry out a simulation test using a bucket or other similar external container.

Determine the desired EC pH target value.

Fill the bucket with the water used for the irrigation/fertilization circuit and measure the EC pH values with a properly calibrated handheld reader.

Using a measuring cup, take one dose from each fertilizer solution and the acid solution (if used) according to the proportions determined by the dosing ratio in the recipe and mix thoroughly with water.

Next, measure the solution with a portable EC pH reader and compare the value with the set target value.

If the values are not within the $\pm 30\%$ adjustment range, check the data and recipe doses again, and repeat the test if necessary. For any doubts, contact the agronomist/consultant.

Example:

- desired target value: EC=2.1; pH=5.7
 - measured value after addition of the solution (fertilizer + acid) EC=1.8; pH=5.3
- Variation of work measured = EC +16%; pH -7% corrected

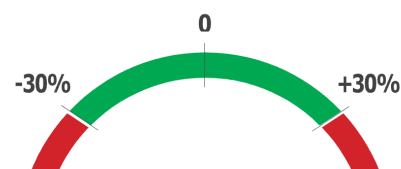

ATTENTION: Excessive EC and pH values can be harmful and damage the crop. Always seek the advice of the consultant and/or agronomist before making any changes to the formula/recipe or application.

5. PROGRAMMING

The Shaker Pro™ fertigation unit is equipped with Commander EVO® Gold controller which allows full programming of irrigation and fertigation parameters.

*Attention

Read the Commander EVO® Gold manual carefully before programming the unit for better knowledge of all controller's features.

Briefly programming of the Commander EVO® Gold controller is as follows:

1. Go to the "BLOCK" menu.
2. Choose one from 64 blocks available for programming.
3. Set water amount or time to irrigate for the block.
4. Add one or several irrigation valves to the block to operate at the same time by entering their numbers (numbers of the outputs to which the valves are connected, including extension or radio valves if present).
5. Set fertigation parameters for the block: time/volume of fertilizers/proportion/EC & pH setpoints (depends on fertigation mode have been chosen).
6. Switch to the next irrigation block if needed and repeat the above programming.

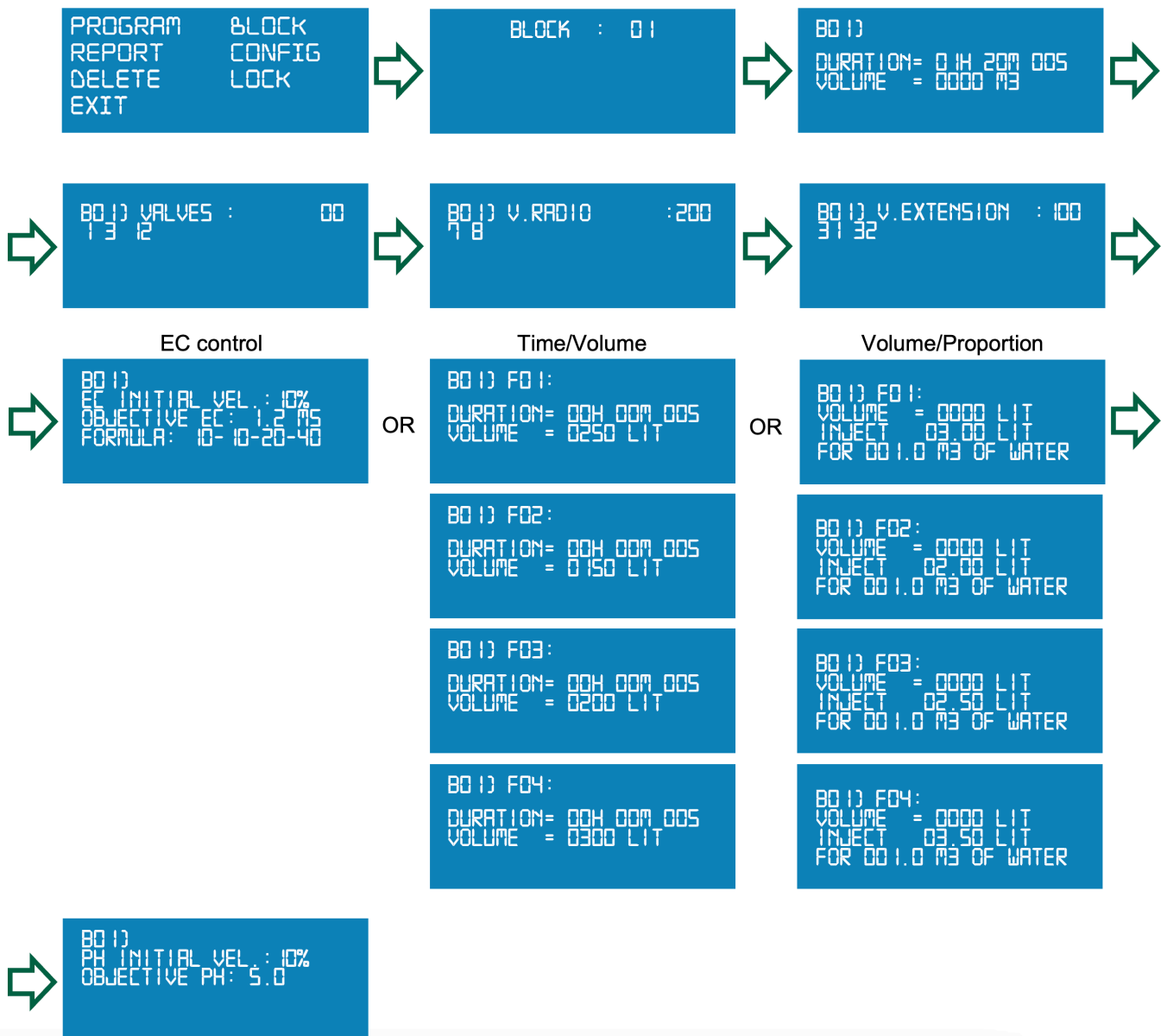

7. After programming irrigation blocks go to the "PROGRAM" menu.
8. Choose one of the 20 programs available.
9. Set if the program is active and its schedule.
10. Add one or several previously set irrigation blocks to the sequence. After finishing the watering task for the first block in sequence, the second will start automatically.
11. Set program start conditions, priority, repetitions and on-alarm behavior if needed.

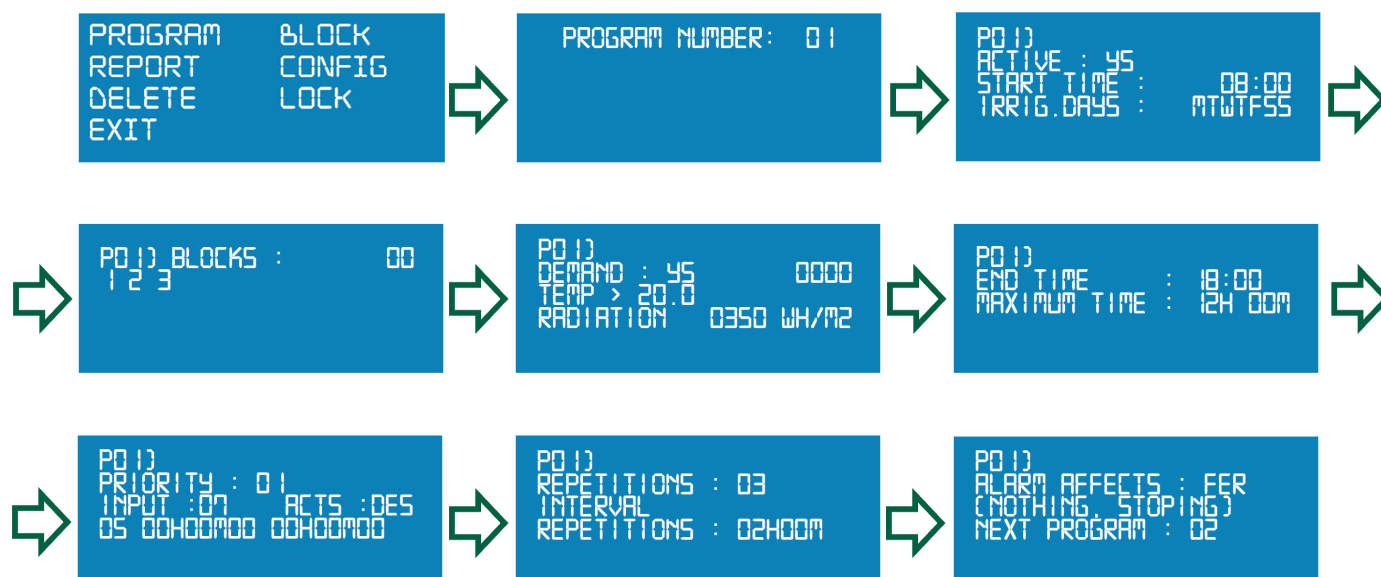

6. MAINTENANCE

In order to ensure the proper functioning and long service life of the components that make up the Shaker Pro™, it is recommended that due care be taken in their use and maintenance. For this reason, we recommend performing a periodic inspection of the system to ensure that all components are working smoothly.

***Attention**

Never perform maintenance or repair of the Shaker Pro™ fertigation unit when the system is under pressure.

Before maintenance/repair set the Commander EVO® Gold on PAUSE from the "Manual deactivation" menu of the controller.

- **Weekly:**
 - Clean the filters of the fertilizer tanks and clean the filter of the injection system.
 - Visually inspect the system for any leaks or air bubbles inside the dosing channels.
 - Verify the readings of the EC and pH sensors are correct and, if necessary, recalibrate them.

- **Monthly:**
 - Clean and calibrate the pH electrode and EC probe.

- **Seasonal / following long periods without use.**
 - Perform a complete cycle using only water.
 - Disconnect the hydraulic fittings.
 - Empty the premixing tank.
 - Discharge and completely drain the channels and fertilizer meters.
 - Protect against frost and extreme temperatures.
 - Before returning them to use, rinse and soak the probes well (at least 1 hour).
 - Repeat the first start-up operations explained in this manual.

NOTE: it is recommended to install a new pH probe at the beginning of a new irrigation season.

All Irritec technical documents are available online from our website www.irritec.com.
For further explanations or information, always consult a qualified or trained technician.

7. TROUBLESHOOTING

Below is the list of the most typical problems which can occur when using the Shaker Pro™ fertigation unit, with possible solutions.

*Attention

Never perform maintenance or repair of the Shaker Pro™ fertigation unit when the system is under pressure.

Before maintenance/repair set the Commander EVO® Gold on PAUSE from the “Manual deactivation” menu of the controller.

Carefully read this Shaker Pro™ unit's manual and the Commander EVO® Gold controller's manual in case of any malfunction.

Electrical installations or repairs can be performed only by qualified electrician.

Problem	Possible reason	Solution
Unable to reach EC/pH setpoint	Incorrect settings of the “Delay” and “Initial Speed” values in the controller	<ul style="list-style-type: none"> Adjust the unit with refer to the corresponding section of this manual
	Incorrect concentration of fertilizers/acid	<ul style="list-style-type: none"> Check the concentration of fertilizers/acid and the dosing formula with refer to the corresponding section of this manual. Change fertilizers/acid concentration in tank if needed
	Incorrect EC/pH sensors readings	<ul style="list-style-type: none"> Compare the sensor readings with a properly calibrated handheld reader. Calibrate the sensor if needed. If it is impossible to calibrate – replace the sensor Check if the EC-pH Transmitter is working properly (see below)
	No injection or low fertilizers/acid flowrate	<ul style="list-style-type: none"> See below
No injection or low fertilizers/acid flowrate (single dosing channel)	Clogged filter on fertilizer tank	<ul style="list-style-type: none"> Check and clean the filter
	Air inside the injection channel	<ul style="list-style-type: none"> Check carefully if all the connections and hoses from the fertilizer tank to the dosing channel are hermetic
	Clogged dosing valve	<ul style="list-style-type: none"> Dismount, disassemble and clean the dosing valve. Carefully check the fertilizers combination recommendations in order to avoid crystallization inside dosing channels
	Clogged venturi	<ul style="list-style-type: none"> Dismount, disassemble and clean the venturi. Carefully check the fertilizers combination recommendations in order to avoid crystallization inside dosing channels
	Dosing valve is not functioning properly	<ul style="list-style-type: none"> Check if the manual override is in CLOSE position Start the corresponding controller's output and check if the power 24 Vac comes to valve's coil (valve's LED must be lit). If it does, but valve doesn't open – replace the valve. If it doesn't – check the cable connections and the presence of power 24 Vac on the corresponding output of Commander EVO® Gold If there is no power on the controller's output – consult your local Irritec® agent

Problem	Possible reason	Solution
No injection or low fertilizers/acid flowrate (multiple dosing channels)	Clogged filter inside Shaker Pro™ unit	<ul style="list-style-type: none"> Check and clean the filter. Check the main filtration system and the fertilizers combination recommendations in order to avoid crystallization inside irrigation pipes
	Incorrect pump's motor rotation	<ul style="list-style-type: none"> Check the direction of unit pump's motor rotation. If incorrect – swap 2 phase wires inside power panel
	Air gap inside unit's pump	<ul style="list-style-type: none"> Loosen the pump's bleeding screw and release the air from impeller chamber
	Not enough pressure/flow for Venturis	<ul style="list-style-type: none"> Check the pressure gauge inside the unit. The optimal working pressure is from 3 to 6 bar If unit's outlet bypass valve is fully opened – close it a little to increase the pressure inside unit
Overflow of the premixing tank	Non-return valve is blocked	<ul style="list-style-type: none"> Check the non-return valve at the unit's outlet. Clean and unblock it. Replace if needed
	Float valve is broken	<ul style="list-style-type: none"> Manually check if the float valve inside the premixing tank fully closes by rising the float. If it doesn't – replace the float valve
Shaker Pro™ pump doesn't start	No fertigation is properly programmed	<ul style="list-style-type: none"> Unit's pump starts only when any type of fertigation is programmed. Carefully check the irrigation/fertigation programming with refer to Commander EVO® Gold manual
	Motor thermic protection has tripped	<ul style="list-style-type: none"> Check motor's thermic protection inside the unit's power panel. If it has tripped – check if the motor's impeller is not blocked or if the premixing tank is not empty
	No power 24Vac on pump's output	<ul style="list-style-type: none"> Check the 24Vac outputs fuse inside the Commander EVO® Gold controller, replace with spare one if needed. Consult the electrician to find the reason for blowing the fuse Check the presence of power 24Vac on the controller's output 23 by activating the output from "Manual activation" menu. If the output is active, but there is no power on terminals – consult your local Irritec® agent
No power on Commander EVO® Gold controller	Power fuse has blown	<ul style="list-style-type: none"> Check the power fuses inside the unit's power box and inside the Commander EVO® Gold controller, replace with spare ones if needed. Consult the electrician to find the reason for blowing the fuse
EC is shown 0.0 on the Commander EVO EVO® Gold controller's screen and doesn't change or pH is shown 9.5 on the Commander EVO EVO® Gold controller's screen and doesn't change	EC (pH) sensor is broken or not connected properly	<ul style="list-style-type: none"> Check the sensor and its connection to the EC-pH transmitter. Replace sensor if broken
	EC-pH Transmitter is not functioning properly	<ul style="list-style-type: none"> Check the power 24Vac coming to the Transmitter (LED must be lit). If there is no power – check the connection to the Commander EVO® Gold controller. If there is a power 24Vac on the input of EC-pH Transmitter, but the LED doesn't light – replace the EC-pH Transmitter board

WARRANTY

All products manufactured by Irritec have a 1-year warranty from the date of purchase.

This warranty covers possible manufacturing defects. Irritec warrants Shaker Pro™ products against manufacturing defects for one (1) year from the date of purchase. Pursuant to this warranty, Irritec accepts sole responsibility to repair, replace with an equivalent product, or refund the amount paid for the purchase of any defective product during the warranty period, upon Irritec's receipt of the product along with a copy of the invoice and a description of the problem, with the cost of shipping paid by the sender. For further information regarding the warranty, call 800 607050 or contact Irritec at the address provided at the end of this manual. This limited warranty does not apply to: (i) normal wear and tear or aging of the product, (ii) accidental loss or damage, misuse, unreasonable use, or neglect, (iii) damage caused by the product or by the system in which the product is used, or (iv) damage caused by maintenance or modifications made to the product by personnel not authorised by Irritec.

THIS IMPLIED WARRANTY AND LIABILITY ARE EXCLUSIVE AND IN LIEU OF ANY WARRANTY, WHETHER IMPLIED OR EXPRESSED (INCLUDING ANY IMPLIED COMMERCIAL WARRANTY WHICH IS TERMINATED).

ALL APPLICABLE WARRANTIES FOR THIS PRODUCT ARE VALID FOR ONE YEAR. IRRITEC SHALL NOT BE LIABLE UNDER ANY CIRCUMSTANCES FOR INCIDENTAL OR CONSEQUENTIAL DAMAGES, INCLUDING BUT NOT LIMITED TO DAMAGES RESULTING FROM THE MALFUNCTION OF THE PRODUCT OR THE SYSTEM IN WHICH THE PRODUCT IS USED, LOSS OF PROFIT OR FROM SPARE PARTS. IN ORDER TO BE VALID, THIS WARRANTY MUST BE DULY COMPLETED AND STAMPED, AND BE ACCOMPANIED BY THE PURCHASE INVOICE.

Modello	Data installazione
Numero di serie	Timbo impresa installatrice



This symbol on the product or on the packaging indicates that this product should not be treated as household waste. Instead, it should be taken to an appropriate collection point for the recycling of electrical and electronic equipment. For more information about the recycling of this product, please contact your local municipal office, your household waste removal service or the store where you purchased this product.

8. CERTIFICATE OF CONFORMITY

This declaration certifies that the Commander EVO® controllers used in fertigation systems comply with the applicable provisions of the following directives:

EMC Directive 2004/108/EC
 Electrical safety: 2006/95/EC

Verification of compliance with the following standards:

UNE-EN 61000-6-4:2007 on electrical safety
 EN 61000-6-3:200 on emissions of radiation and conductivity
 EN 61000-6-1:2001 regarding EMC



Via Gambitta Conforto, C.da S. Lucia SNC - 98071 Capo d'Orlando (ME) – Italy
Tel. +39 0941 922111 - Fax. +39 0941 958807

www.irritec.com

